



Series Model

- SL-200D :With lock status indicator and door position detection output (NO/NC)
- SL-200SD:Without indicator lights

Special features

- 600lbs(250Kg) holding force for double door leaf.
- Suitable for all types of 90° double push/pull door.
- Power Supply: DC12V or DC24V (adjustable)
- Fail-safe (power to lock) electric lock suitable for fire exit.
- Special surface enhancement process which is anti-rust for its durability.
- For use with any types of the access control unit with built-in surge absorber to prevent any interference to the reader.
- Special aluminum hardening, all materials used are fireproof.
- Monitor output with Hall Effect for its stability and high accuracy.

Specification		Dimensions
	SL-200SD	SL-200D
Lock status sensor	X	N.C. & N.O. Output (1A@30VDC)
Indicator	X	Double-colored LED light
Power Supply	DC 12V or DC24V ± 15%	
Operation current	450mA@12VDC mA ± 5% 230mA@24VDC mA ± 5% (Single side)	
Application	Exit door ,Out-swing door and In-swing door	
Holding forces	600lbs(250Kg) (Single side)	
Demagnetizer design	Instant demagnetizer when power is off.	
Operation temperature	40°C ± 5°C (Room temperature 30°C)	
Weight	4300g (included wrapping)	

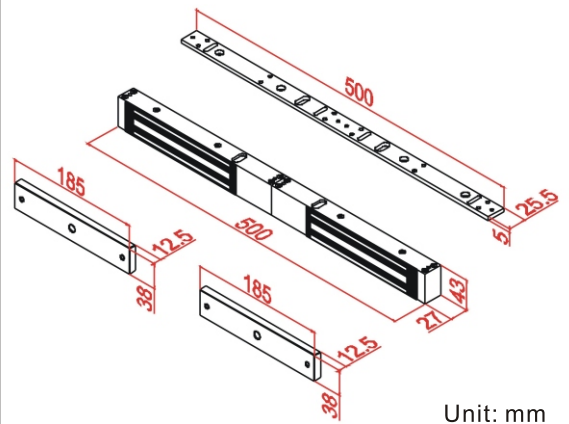

Unit: mm

Related products

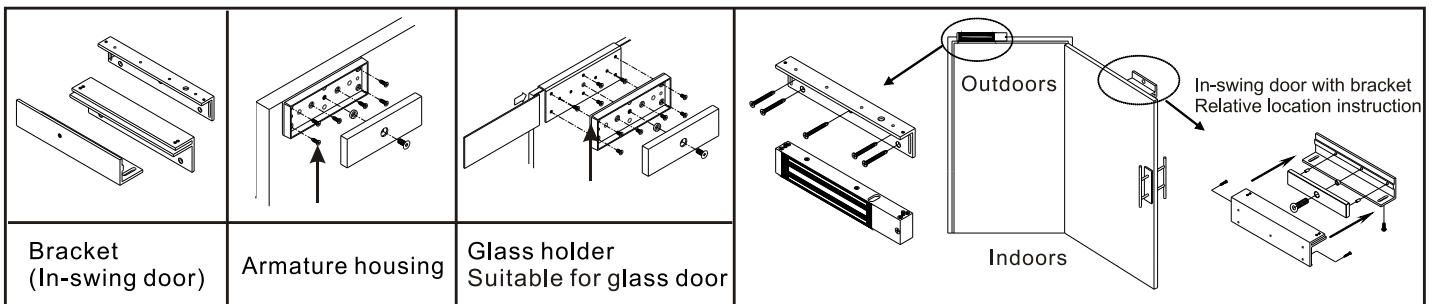

Structure diagram

【Out-swing door】

【In-swing door】

