

Series Model

- SL-130A : DC12V, N.C. door position detection output
- SL-130U : DC12V~24V , Door position detection and bolt position (N.C. & N.O.) output points.

Special features

- Door position detection and bolt position output points.
- Door position detection output, available for security unit use.
- Special wearable design. Mechanic life of more than 500,000 times.
- Adjustable fail-safe (power to lock) or fail-secure (power to open). Suitable for all types of 90~180° door.
- Micro computer door position detection and current control to prevent error action and lower the lock's temperature.
- Stainless steel bolt is able to sustain more than 800 kg of shear force.
- Built-in photo coupler door open push button input contact. Door will lock again automatically when door is not open within 5 seconds.

Specification

	SL-130A	SL-130U	
Power Supply	DC 12V	DC 12V	DC24V
Operation current	880mA	900mA	450mA
Holding current	250mA	250mA	120mA
Door position detection points	N.C.	N.C.&N.O.	
Bolt position points	x	N.C.&N.O.	
Relock Function	x	x	
Application	all types of 90~180° door		
Delay Time	0,3,5,9 Sec.(Available to set)		
Mechanic life	more than 500,000 times		
Door Open Contact	Photo coupler contact		
Overloaded Current Protection	Available		
Operation temperature	Usual:0°C / Long unlocked: 50°C± 5°C		
Range of the door crack	Maximum of 10 mm		
Legth of bolt	16mm		
Weight	750g (included wrapping).		

Dimensions

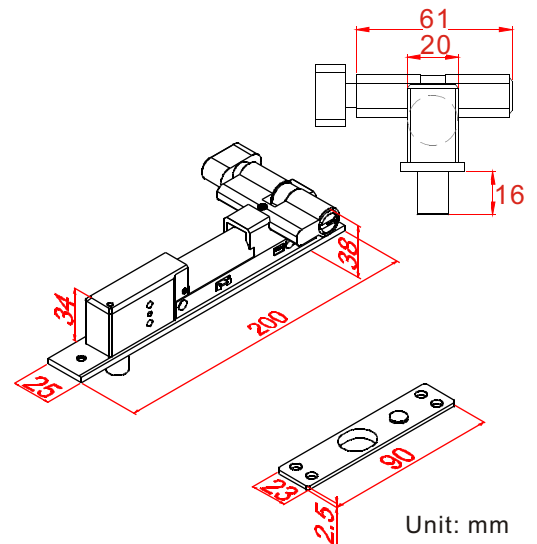

Structure diagram

※ Please note the width limitation of door leaf.

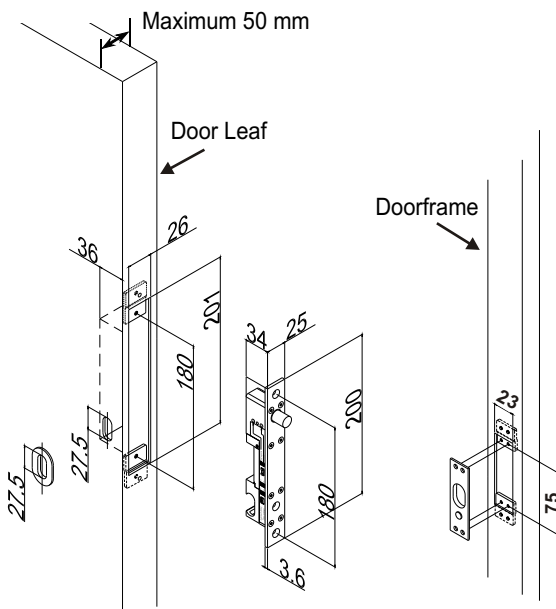

※ The correct installation position of the electric lock the door leaf, not on the door frame.

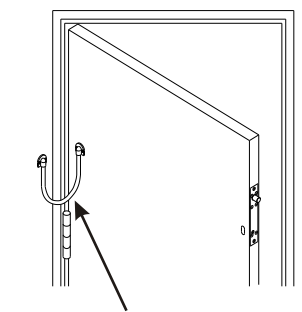
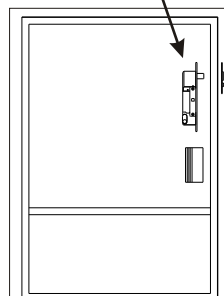

Armored Door Loop (Optional)

※ Door position detection output:

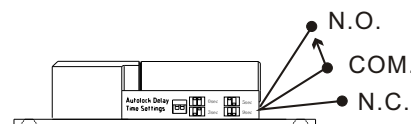

When door is not closed, detection output is COM and N.O. Connected.

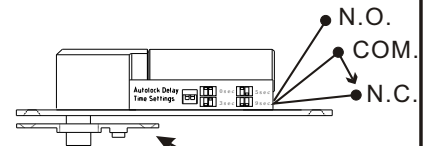

When door is closed, detection output is COM and N.C. Connected.