



## **LC-MS1000P** Paniclock mini

### **Installation and Operating Instructions**

# Table of Contents

<b>1.</b>	<b>Document Information</b>	<b>3</b>
1.1	Contents and Purpose	3
1.2	Target Group	3
<b>2.</b>	<b>Safety and Compliance</b>	<b>4</b>
2.1	Safety Information	4
2.2	Regulatory Compliance Information	5
<b>3.</b>	<b>Product Information</b>	<b>7</b>
3.1	Product Description	7
3.2	Package Contents	8
3.3	Technical Data	9
<b>4.</b>	<b>Product Dimensions</b>	<b>10</b>
4.1	Lock Dimensions	10
4.2	Strike Dimensions	11
4.3	Housing Dimensions ( <i>Available Separately</i> )	12
4.4	Dress Plate Dimensions ( <i>Available Separately</i> )	12
4.5	Fitting Tab Dimensions ( <i>Available Separately</i> )	13
<b>5.</b>	<b>Pre-Installation Assessment</b>	<b>14</b>
5.1	Mounting Assessment	14
5.2	Wiring Assessment	15
5.3	Operating Mode Assessment	15
<b>6.</b>	<b>Mounting</b>	<b>16</b>
6.1	Mortice Installation (Solid Wood)	16
6.2	Mortice Installation (Metal Extrusion)	17
6.3	Surface Mounting Installation (Solid Wood)	18
6.4	Surface Mounting Installation (Glass)	19
<b>7.</b>	<b>Wiring</b>	<b>20</b>
7.1	Wiring Guide	20
7.2	Fail Safe Connection	20
7.3	Fail Secure Connection	20
<b>8.</b>	<b>Operating Mode</b>	<b>21</b>
8.1	Fail Safe Operation	21
8.2	Fail Secure Operation	21
<b>9.</b>	<b>Maintenance</b>	<b>22</b>
9.1	Maintenance and Cleaning	22
9.2	End of Service Life	22

# 1. Document Information

## 1.1 Contents and Purpose

This document describes installation, connection, operation, and maintenance of the lock [LC-MS1000P](#). Read the document carefully and observe the instructions it contains. They contain important information for reliable installation and trouble-free operation.

## 1.2 Target Group

Target group of these instructions are:

- Installer
- Service Technician

Installers and service technicians are skilled personnel who have the specialist knowledge required for installation, commissioning, and maintenance.

## 2. Safety and Compliance

### 2.1 Safety Information



#### **WARNING**

- Live parts inside.
- The handling and installation of this device is recommended for a professional.
- Use of an unsuitable power supply unit may cause product failure or injury.
- Do not remove the cover plates or face plate.
- Ensure installation does not expose sharp edges of the product to users.

## 2.2 Regulatory Compliance Information



This product is in compliance with the CE Directives including Electromagnetic Compatibility (EMC) Directive, Restriction of the use of certain hazardous substances (RoHS) Directive, and Registration, Evaluation, Authorisation and Restriction of Chemicals (REACH) Regulation. EU Declaration of Conformity is available at [www.bqtsolutions.com](http://www.bqtsolutions.com).



This product is in compliance with the United Kingdom (UK) Legislation including the Electromagnetic Compatibility Regulation 2016, and the Restriction of the Use of Certain Hazardous Substances in Electrical and Electronic Equipment Regulations 2012. UKCA Declaration of Conformity is available at [www.bqtsolutions.com](http://www.bqtsolutions.com).



This product is in compliance with the Regulatory Compliance Mark (RCM) for Australia and New Zealand.

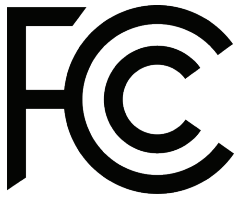

This device complies with Part 15 of the FCC Rules. Operation is subject to the following two conditions:

1. This device may not cause harmful interference.
2. This device must accept any interference received, including interference that may cause undesired operation.

**Note:** This equipment has been tested and found to comply with the limits for a Class B digital device, pursuant to Part 15 of the FCC Rules. These limits are designed to provide reasonable protection against harmful interference when the equipment is operated in a residential, commercial, or industrial environment. This equipment generates, uses, and can radiate radio frequency energy and, if not installed and used in accordance with the instruction manual, may cause harmful interference to radio communications. However, there is no guarantee that interference will not occur in a particular installation.

**Modifications:** Any modifications made to this device that are not approved by the manufacturer may void the authority granted to the user by the FCC to operate this equipment.

**Innovation, Science and Economic Development Canada ICES-003:**  
CAN ICES-3(B)/NMB-3(B)

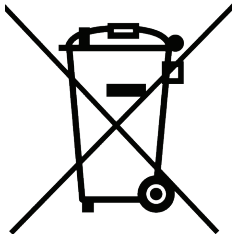

**In the European Union, Norway, Iceland and Liechtenstein:** This symbol on the product, or in the manual and in the warranty, and/or on its packaging indicates that this product shall not be treated as household waste. Instead it should be taken to an applicable collection point for the recycling of electrical and electronic equipment.

By ensuring this product is disposed of correctly, you will help to prevent potential negative consequences to the environment and human health, which could otherwise be caused by inappropriate handling of this product.

**In Countries Outside the European Union, Norway, Iceland and Liechtenstein:** If you wish to dispose of this product please contact your local authorities and ask for the correct way of disposal.

## 3. Product Information

### 3.1 Product Description

The [LC-MS1000P](#) is a motor driven low voltage electric lock designed to secure commercial and residential doors. The lock has been designed to address the two biggest issues in concealed electric locking today;

1. The ability to 'pull' a door into alignment even if the door has not closed in a central position.
2. The ability to release when requested even if there is excessive load on the door.

The bolt pin of the [LC-MS1000P](#) operates on a cam action which enables the bolt pin to pull a door into place. In practice as the door closes it may come to rest in a position that is not fully closed, especially if it closing against a door seal of some type. The [LC-MS1000P](#) senses when the door is within 8mm ( $\frac{5}{16}$  inch) of being fully closed and activates the bolt pin. The bolt pin then rotates out and pulls the door from its resting position to the closed and sealed position.

With the door secured and locked the [LC-MS1000P](#) can be given an unlock signal and it will instantly unlock. If the door is loaded (pre-load) when the unlock signal is given the [LC-MS1000P](#) will still unlock, even with loads in excess of 500kg on the door. Critically, the ability of the [LC-MS1000P](#) to instantly release with excessive pre-load on the door even occurs in the event of a power failure, providing the lock is configured as fail safe.

Additional features of the [LC-MS1000P](#) are;

- Multi-voltage input (12 - 24VDC)
- Very low current consumption
- Door position and bolt position monitors
- High physical strength
- Fail-safe / Fail-secure on-site conversion with the re-positioning of a single switch

### 3.2 Package Contents

<p><b>1x Lock</b></p> 	<p><b>1x Strike Plate</b></p> 
<p><b>4x 10G self-tapping screws</b></p> 	<p><b>1x 300mm 7-way wire loom</b></p> 



### 3.3 Technical Data

<b>Materials</b>		
Bolt	Stainless Steel 17-4PH	
Lock / Strike Plate	Stainless Steel 304	
<b>Mechanical</b>		
Bolt Extension	13mm	
Door Gap	max. 6mm (¼ inch)	
Misalignment Correction	max. 8mm (5/16 inch)	
Cycle Life	1,000,000 cycles	
Holding Force	10,000N (2,250 lbf) (factory tested)	
Side Load Release	6,000N (1,350 lbf) (factory tested)	
Locking Time	1.0 seconds (typical)	
Unlocking Time	0.3 seconds (typical)	
<b>Electrical</b>		
Power Requirements	12-24 VDC ±15%	
	Initial Power Up Time	11 seconds
	Initial Power Up Current	750mA@12VDC, 400mA@24VDC
	Standby Current	40mA@12VDC, 25mA@24VDC
Signal Contacts	Bolt Position (NO)	30VDC max., 100mA max.
	Door Position (NO)	
<b>Compliance</b>		
CE, UKCA, FCC, IC, RCM, RoHS 2		

# 4. Product Dimensions

## 4.1 Lock Dimensions

The dimensions shown are approximate and subject to change without prior notice.

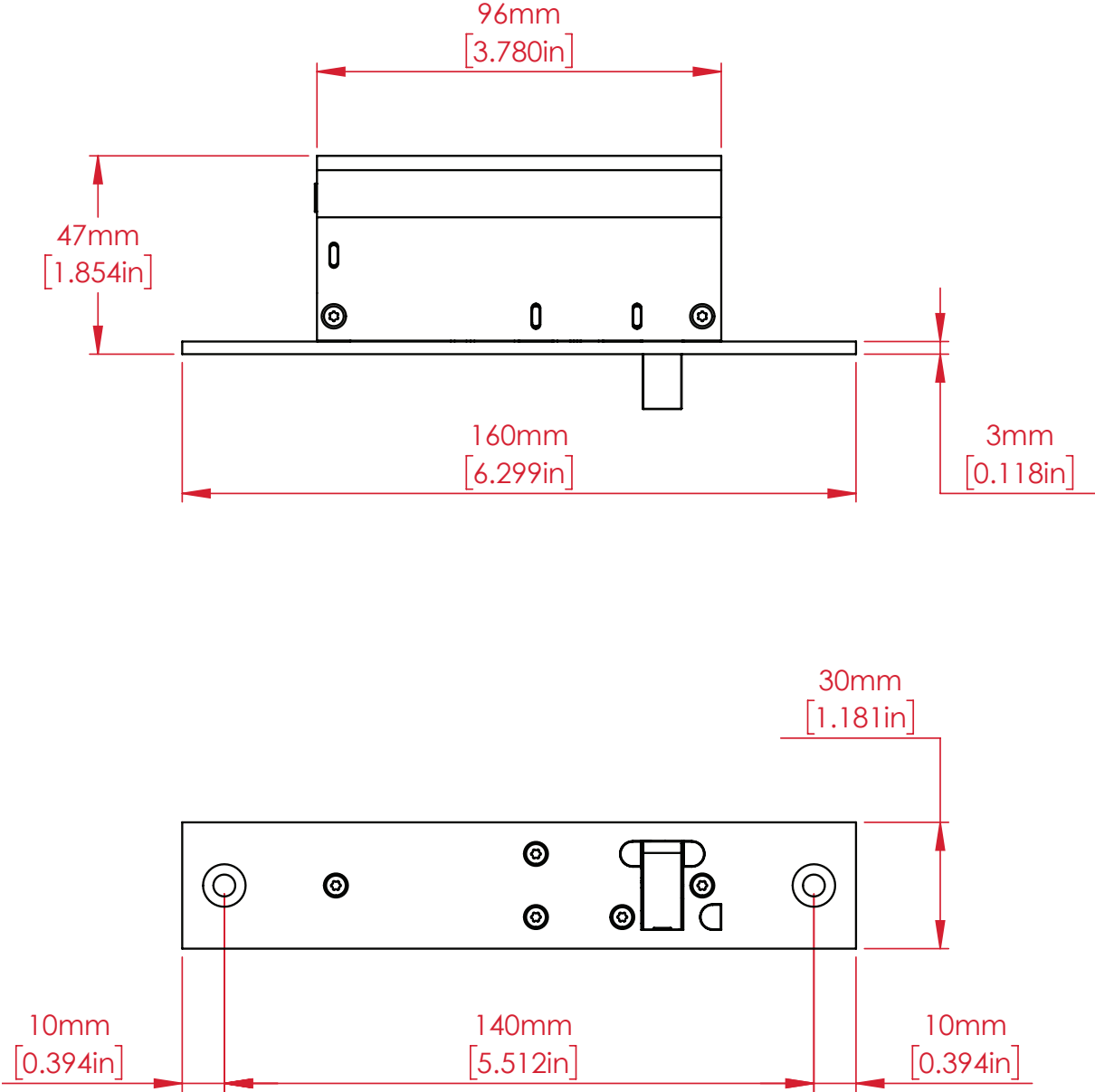

## 4.2 Strike Dimensions

The dimensions shown are approximate and subject to change without prior notice.

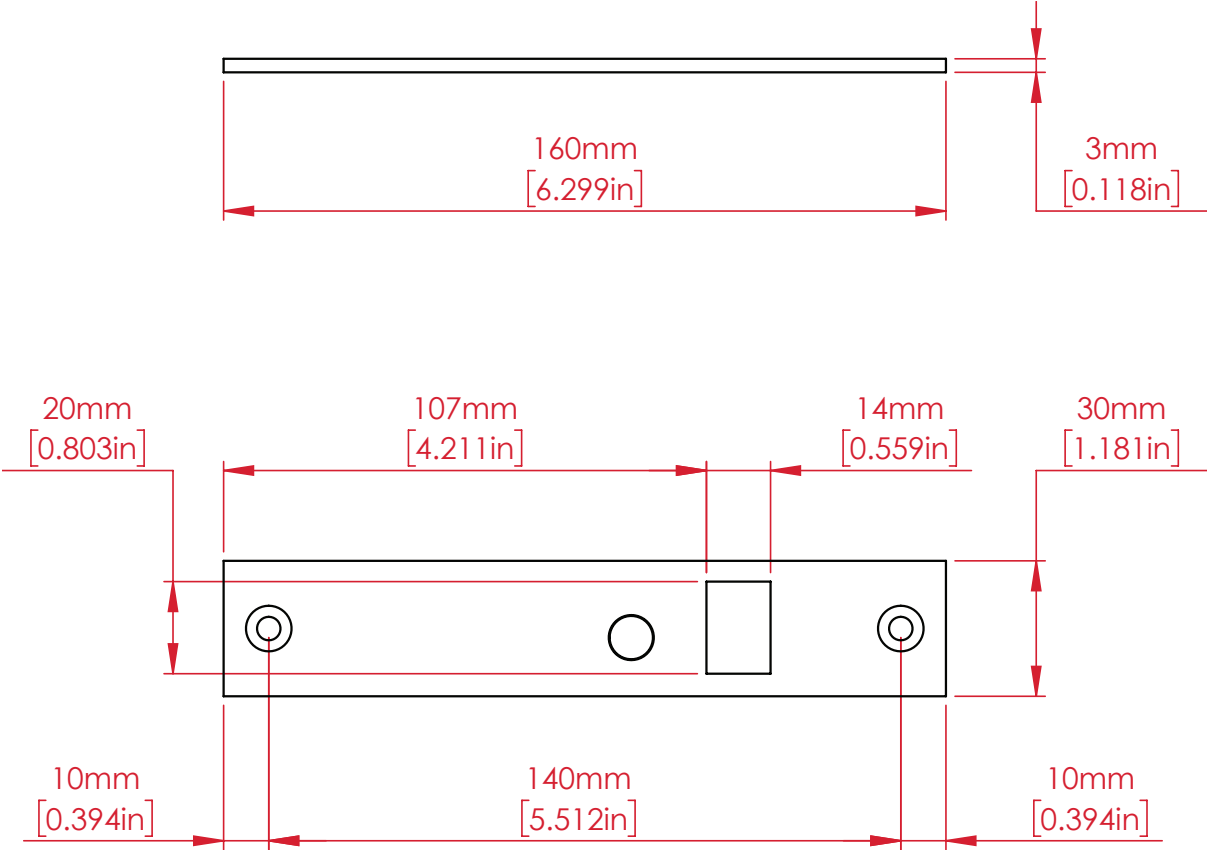

### 4.3 Housing Dimensions (Available Separately)

The dimensions shown are approximate and subject to change without prior notice.

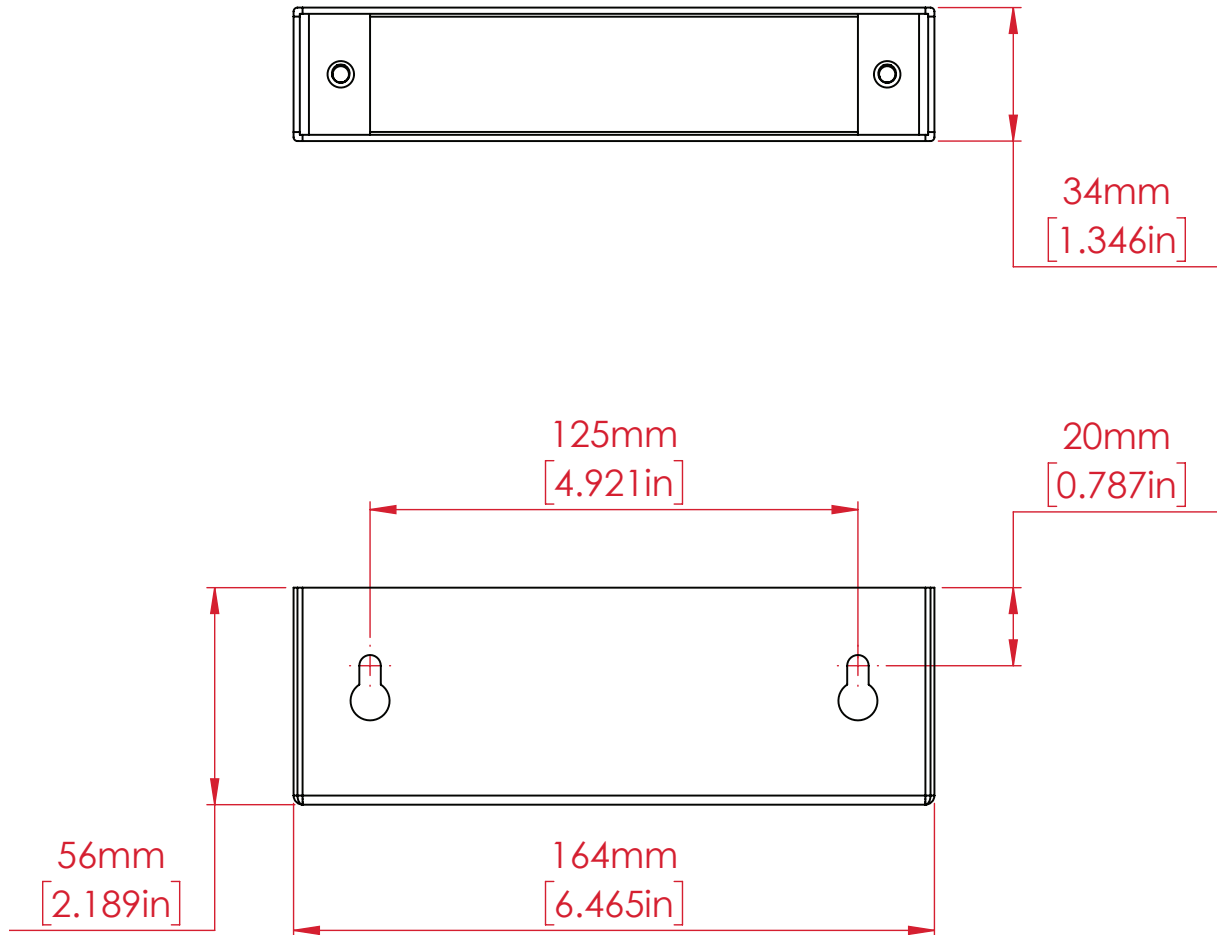

### 4.4 Dress Plate Dimensions (Available Separately)

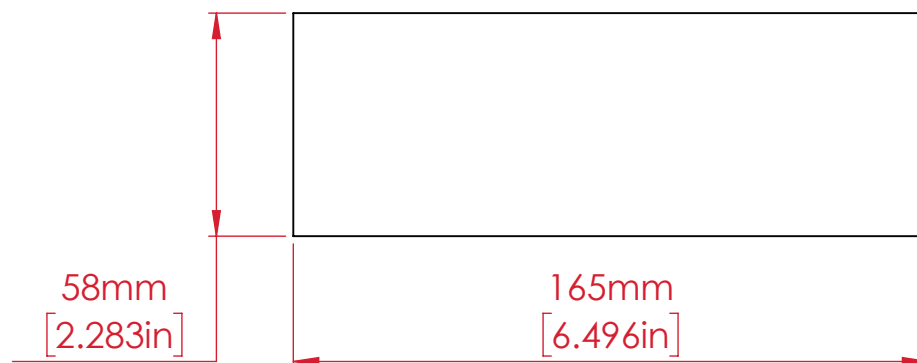

### 4.5 Fitting Tab Dimensions (Available Separately)

The dimensions shown are approximate and subject to change without prior notice.

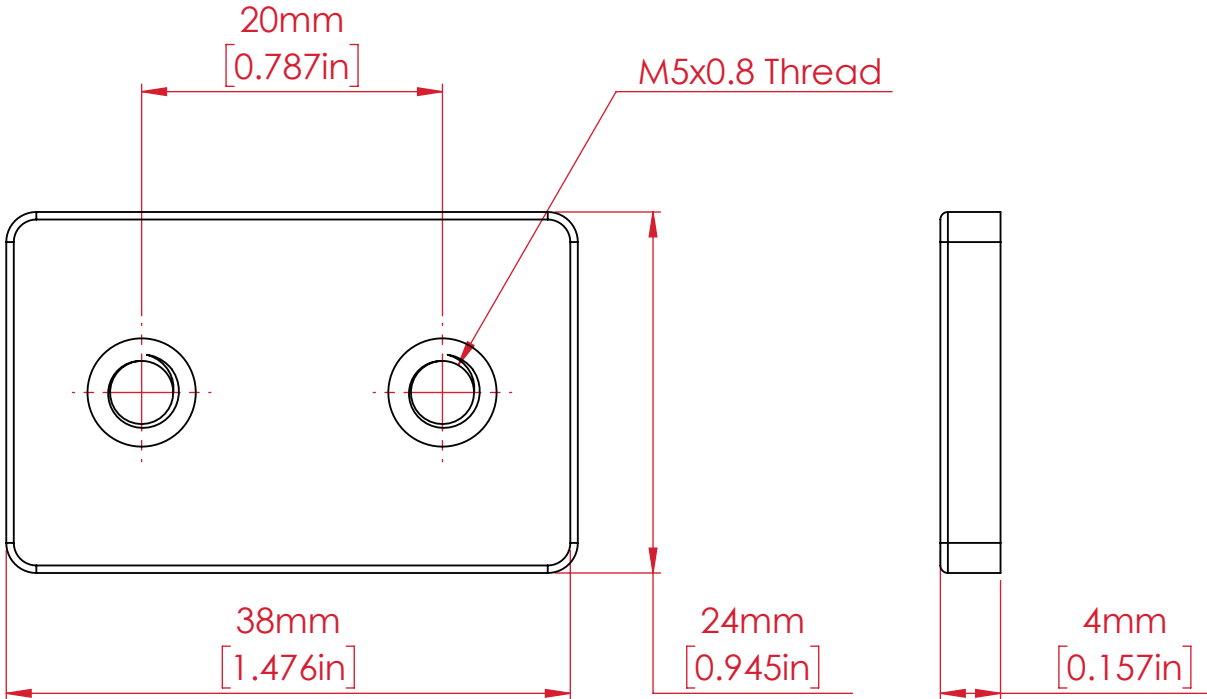

## 5. Pre-Installation Assessment

### 5.1 Mounting Assessment

The first decision regarding installation is whether the **LC-MS1000P** will be morticed or surface mounted. Mortice installation ensures a discrete solution as the lock and strike plate can be embedded into the door leaf and frame, however in some instances this is not possible. Glass doors for example require surface mounting which is done with the aid of the **LC-MS1000P** housing and dress plate (available separately).

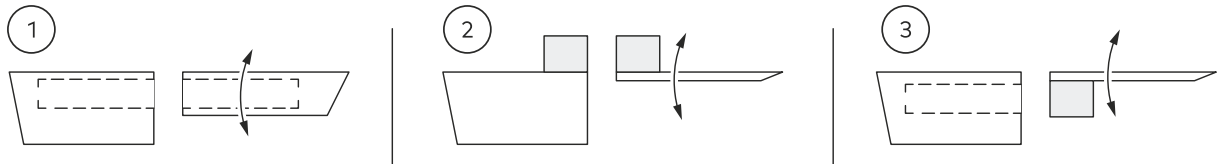

The lock and strike plate can be installed morticed (1), surface mounted (2), or a combination of the two (3). Regardless of the installation method it is vital that the lock face plate and strike plate are aligned vertically to each other and that the gap between them does not exceed 6mm ( $\frac{1}{4}$  inch) when the door is closed.

When the door is closed, the resting position of the door leaf can be misaligned up to 8mm ( $\frac{5}{16}$  inch) from the door frame and the **LC-MS1000P** will pull the door into alignment with ease. This misalignment could be caused by an installed weather seal or natural distortions in the door assembly.

The **LC-MS1000P** can be installed vertically or horizontally but is not designed to be mounted in a floor cavity firing upwards or in a wet environment.

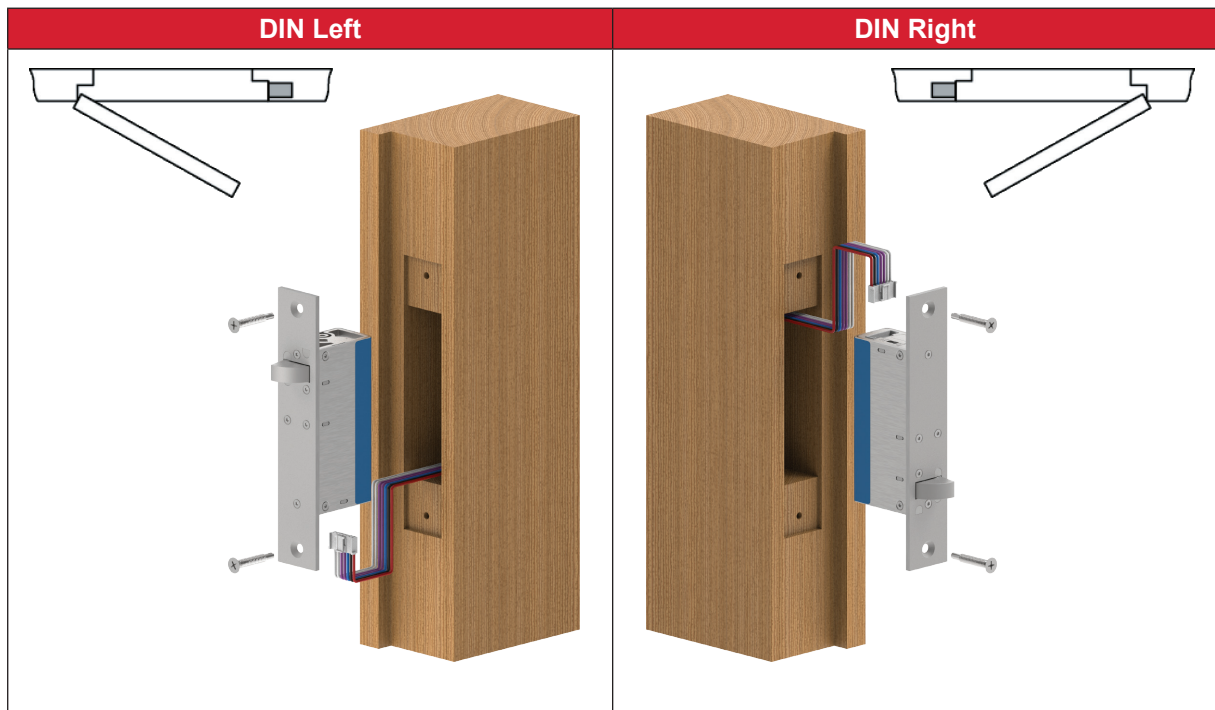

## 5.2 Wiring Assessment

Before installation begins, consideration must be made for where to run the wires and decide on what feedback is required from the lock. There are a total of seven available connections; three are compulsory power/control connections whilst the remaining four provide optional door and bolt position feedback. These optional connections can be integrated into access control or alarm systems to provide full monitoring.

The correct gauge of wire needs to be chosen as voltage drop across the power/control wires can limit the locks operation. For all the remaining connections, a lower gauge wire can be used as these are only signal wires. The following table shows the maximum distance that the wire runs can be between the power supply and the lock, assuming the power supply outputs 12VDC or 24VDC.

Conductor Cross Sectional Area		Maximum Distance	
#AWG	(mm <sup>2</sup> )	at 12VDC	at 24VDC
24	0.20	10m (33ft)	30m (98ft)
22	0.33	16m (52ft)	48m (157ft)
20	0.52	26m (85ft)	77m (253ft)
18	0.82	41m (135ft)	122m (400ft)
16	1.31	65m (213ft)	195m (640ft)
14	2.08	103m (338ft)	310m (1017ft)

## 5.3 Operating Mode Assessment

The [LC-MS1000P](#) can be set to one of two operating modes before installation, Fail Safe or Fail Secure.

When the operating mode is set to Fail Safe, supply voltage is applied to the control input to lock the door, and the [LC-MS1000P](#) will unlock in the event of power loss.

When the operating mode is set to Fail Secure, supply voltage is applied to the control input to unlock the door, and the [LC-MS1000P](#) will lock or remain locked in the event of power loss.

The failure mode of the [LC-MS1000P](#) is factory set as Fail Safe. Before the lock is installed this can be changed to Fail Secure by repositioning the switch located at the end of the product.

## 6. Mounting

### 6.1 Mortice Installation (Solid Wood)

#### 1. Cutting the mortice

Referring to the product dimension drawings, a mortice is cut into the door frame to fit the lock and a mortice is cut into the door leaf to fit the strike. Wooden doors and frames require full mortices with space made behind the lock body to accommodate the wire connections.

It is crucial to ensure that the mortices in the door leaf and frame are aligned vertically and horizontally when the door is closed as this aligns the bolt pin to the strike opening and also the strike magnet to the locks internal door position sensor.

Ensure that the final gap between the lock face plate and strike plate once it is installed will be no more than 6mm ( $\frac{1}{4}$  inch).

#### 2. Wiring the lock

A hole needs to be drilled in the back of the mortice to bring the wires out and a connection can be made to the supplied wire loom which in turn plugs into the lock.

*Refer to the Wiring section of this document for detailed instructions on wiring.*

#### 3. Setting the operating mode

Ensure the operating mode switch is positioned to the required state, Fail Safe or Fail Secure.

*Refer to the Operating Mode section of this document for detailed instructions on wiring.*

#### 4. Fitting the lock and strike plate

The lock can be slid back into the door frame mortice, ensuring that the wiring integrity is maintained, and then secured in place with the supplied 10G self-tapping screws. Please ensure the lock is the correct orientation as to pull the door into the door jamb.

The strike is then placed into the door leaf mortice and the remaining 10G self-tapping screws are used to secure it in place. Ensure the strike is oriented so that the bolt hole aligns with the lock bolt.

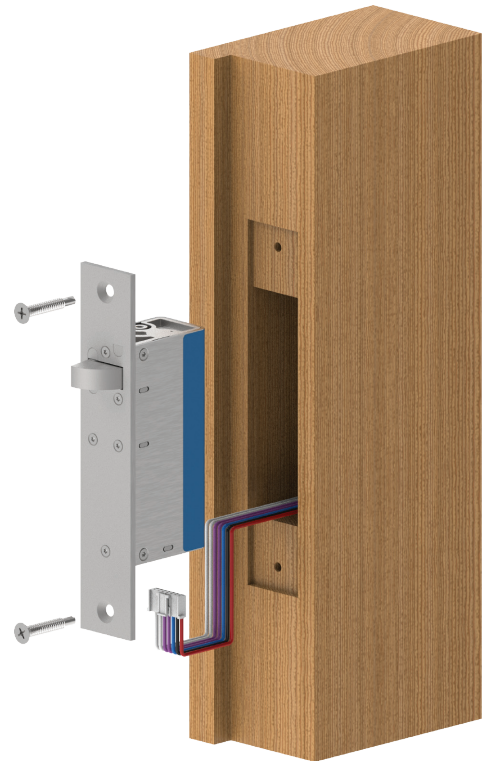



## 6.2 Mortice Installation (Metal Extrusion)

### 1. Cutting the mortice

Referring to the product dimension drawings, a mortice is cut into the door frame to fit the lock and a mortice is cut into the door leaf to fit the strike. Metal doors and frames, being hollow, often only require a single rectangle cut-out to accommodate the lock face plate or strike plate. For these installations lock and strike can be installed flush using fitting tabs (*available separately*).

It is crucial to ensure that the mortices in the door leaf and frame are aligned vertically and horizontally when the door is closed as this aligns the bolt pin to the strike opening and also the strike magnet to the locks internal door position sensor.

Ensure that the final gap between the lock face plate and strike plate once it is installed will be no more than 6mm ( $\frac{1}{4}$  inch).

### 2. Wiring the lock

Feed the wires out of the hollow chamber of the frame and a connection can be made to the supplied wire loom which in turn plugs into the lock.

*Refer to the Wiring section of this document for detailed instructions on wiring.*

### 3. Setting the operating mode

Ensure the operating mode switch is positioned to the required state, Fail Safe or Fail Secure.

*Refer to the Operating Mode section of this document for detailed instructions on wiring.*

### 4. Fitting the lock and strike plate

The lock can be placed into the door frame cutout, ensuring that the wiring integrity is maintained, and then secured in place with M5 machine screws (*included with fitting tabs*). Please ensure the lock is the correct orientation as to pull the door into the door jamb.

The strike is then placed into the door leaf cutout and then M5 machine screws (*included with fitting tabs*) are used to secure it in place. Ensure the strike is oriented so that the bolt hole aligns with the lock bolt.

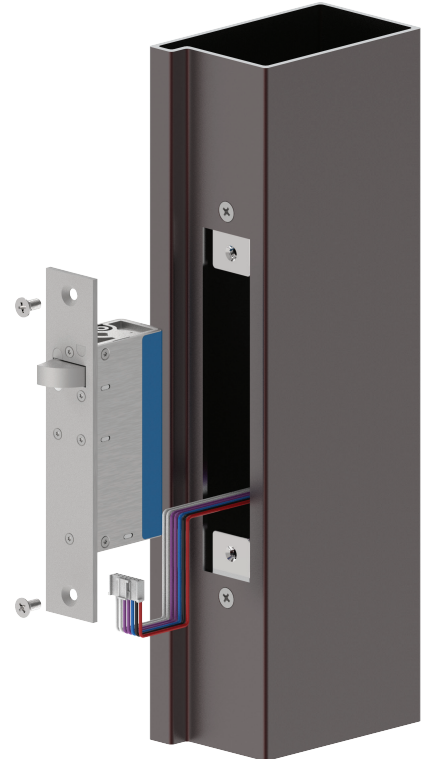

## 6.3 Surface Mounting Installation (Solid Wood)

### 1. Preparing the mounting surface

Install two 10Gx1" self-tapping screws (*included with housing*) in the mounting surface, as per the product dimension drawings they should be 125mm apart, 20mm from the surface edge.

### 2. Preparing the housing

An 8mm hole should be drilled through the housing wall at the position chosen by the installer for the wiring to enter. The wiring can be guided to the housing through surface mount conduit, or through a hole in the mounting surface material. Push a rubber grommet (*included with housing*) over the drilled hole to protect the wires from any sharp edges.

### 3. Fitting the housing

Position the keyhole cutouts of the housing over the screw heads and slide into position flush with the surface edge, and then tighten screws in place to secure the housing.

### 4. Wiring the lock

Feed the wires through the 8mm hole in the housing and a connection can be made to the supplied wire loom which in turn plugs into the lock.

*Refer to the Wiring section of this document for detailed instructions on wiring.*

### 5. Setting the operating mode

Ensure the operating mode switch is positioned to the required state, Fail Safe or Fail Secure.

*Refer to the Operating Mode section of this document for detailed instructions on wiring.*

### 6. Fitting the lock

The lock is then placed into the housing, ensuring that the wiring integrity is maintained, and then secured in place with M5 machine screws (*included with housing*). Please ensure the lock is the correct orientation as to pull the door into the door jamb.



## 6.4 Surface Mounting Installation (Glass)

### 1. Fitting the housing

Clean the glass surface with isopropyl alcohol and peel the protective layer from the double sided tape of the housing. Position the housing flush with the edge of the glass, and press down to adhere tape to surface.

### 2. Fitting the dress plate

Clean the glass surface with isopropyl alcohol and peel the protective layer from the double sided tape of the dress plate. Position the dress plate flush with the edge of the glass and centered on the housing location, and press down to adhere tape to surface.

### 3. Fitting the strike plate

The strike is then placed into the housing and then secured in place with M5 machine screws (*included with housing*). Ensure the strike is oriented so that the bolt hole aligns with the lock bolt.

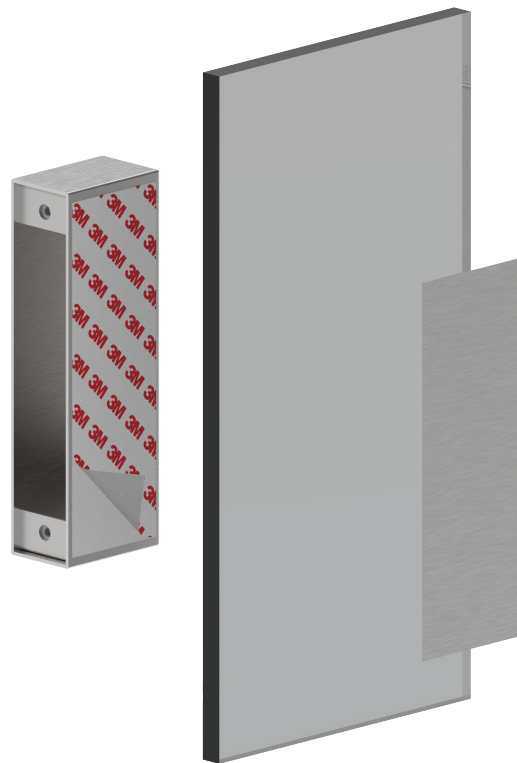

## 7. Wiring

### 7.1 Wiring Guide

The **LC-MS1000P** is supplied with a 7-way wire loom that plugs directly into the lock. The wires are colour coded as per table below, with the power and control wires being essential connections and the four monitor connections being optional.

Wire Colour	Meaning	Description
<b>RED</b>	Power Supply (12 - 24VDC)	Positive connection to DC power supply, “+”
<b>BLACK</b>		Negative connection to DC power supply, “-”
<b>BLUE</b>	Control	Switched positive control input
<b>VIOLET</b>	Bolt Position Monitor	Normally open contact (NO), closed when the bolt pin is extended ( <i>optional</i> )
<b>VIOLET</b>		
<b>WHITE</b>	Door Position Monitor	Normally open contact (NO), closed when the strike is aligned with the lock ( <i>optional</i> )
<b>WHITE</b>		

### 7.2 Fail Safe Connection

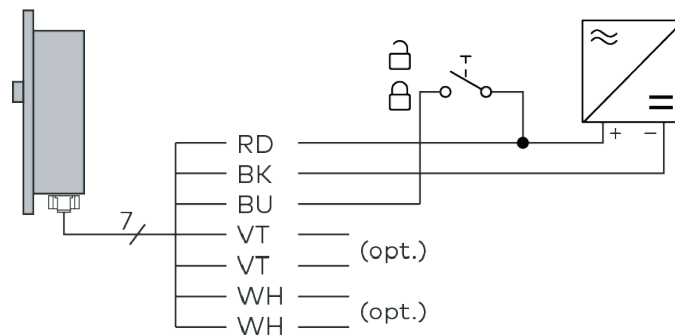

When in Fail Safe configuration, applying positive voltage to the control wire triggers the **LC-MS1000P** to lock (active-high locking signal). In the event of a power cut, the **LC-MS1000P** will unlock.

### 7.3 Fail Secure Connection

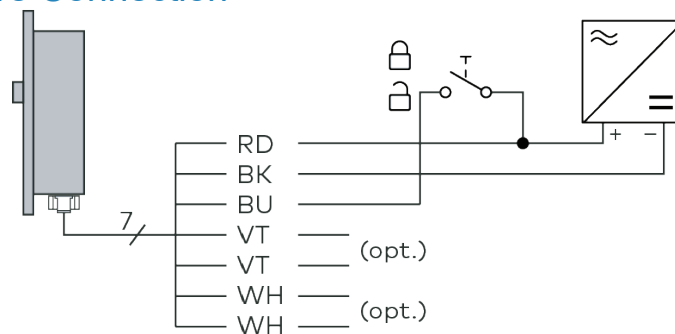

When in Fail Secure configuration, applying positive voltage to the control wire triggers the **LC-MS1000P** to unlock (active-low locking signal). In the event of a power cut, the **LC-MS1000P** will remain locked.

## 8. Operating Mode

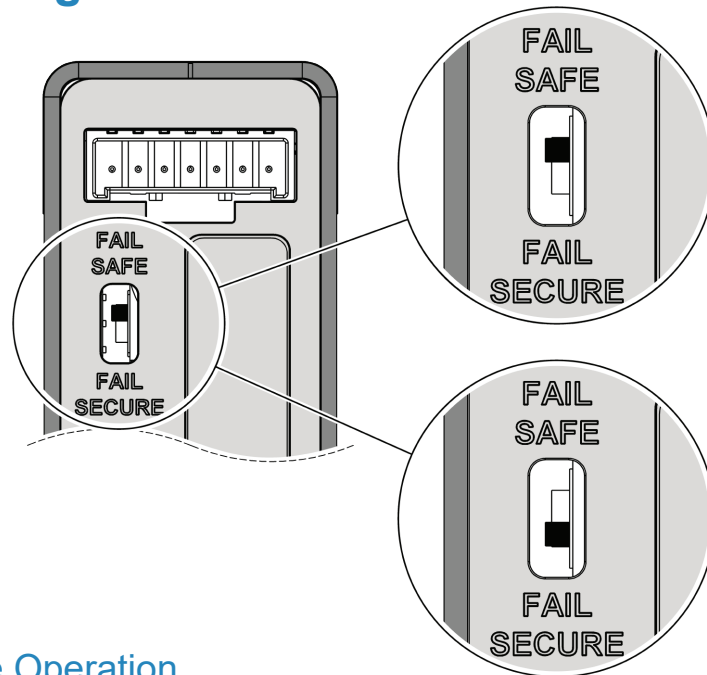

### 8.1 Fail Safe Operation

Assume the lock is installed, wired, and set to fail safe. The door is open and the positive supply voltage is applied to the **BLUE** wire. As the door closes the **LC-MS1000P** senses the door approaching and activates the bolt pin to pull the door into alignment. The Bolt Position and Door Position monitors will have changed to closed contact state as the door is closed and secured.

To unlock the door, the voltage is removed from the **BLUE** wire. The **LC-MS1000P** will immediately release and will do so even when significant load is being applied to the door. With the door now open the Bolt Position and Door Position monitors change to open contact state. The **LC-MS1000P** will remain unlocked as long as the door is open but will instantly re-lock when voltage is applied to the **BLUE** wire and the door is closed.

In the event of a power failure, the **LC-MS1000P** unlocks.

### 8.2 Fail Secure Operation

Assume the lock is installed, wired, and set to fail secure. The door is open and the positive supply voltage is removed from the **BLUE** wire. As the door closes the **LC-MS1000P** senses the door approaching and activates the bolt pin to pull the door into alignment. The Bolt Position and Door Position monitors will have changed to closed contact state as the door is closed and secured.

To unlock the door, the voltage is applied to the **BLUE** wire. The **LC-MS1000P** will immediately release and will do so even when significant load is being applied to the door. With the door now open the Bolt Position and Door Position monitors change to open contact state. The **LC-MS1000P** will remain unlocked as long as the door is open but will instantly re-lock when voltage is removed from the **BLUE** wire and the door is closed.

In the event of a power failure, the **LC-MS1000P** will lock, or remain locked, if the door is closed.

## 9. Maintenance

### 9.1 Maintenance and Cleaning

The lock has been factory lubricated for life and is maintenance free. The use of other lubricants is not permitted and will void the warranty.

This lock contains electromechanical and electronic components that are subject to wear and tear depending on use and on-site installation conditions. The manufacturer has no influence on these factors. As a result of this wear, the lock may fail at the end of its normal service life.

Interval	Activity
As needed:	Using a dry cloth, polish the face plate and strike plate. Note: Look for traces of dirt and wear (dust, escaping lubricant).
Periodically, depending on frequency of use (to be determined by the operator):	Check for: <ul style="list-style-type: none"><li>• Tight fit</li><li>• Smooth running</li><li>• Noise during operation</li><li>• Play of the latch</li><li>• Contamination</li><li>• Escaping lubricant</li><li>• Moisture</li></ul> If there are unusual noises, noticeable play, escaping lubricant or similar; replace the lock.

### 9.2 End of Service Life

The capacitors of the lock are required to provide the fail safe and fail secure operation when power is lost. If a capacitor is compromised, it must be detected to ensure the failure operation can occur while the lock is still being supplied power as it will no longer occur after power is lost.

The lock undergoes daily health checks on the capacitors. If a capacitor is found to be compromised the failure operation will occur, based on the position of the failure mode switch. Once this occurs, the lock will no longer operate. This operation will not work if the lock is wired using only two wires.