

# Heimdall 150 v2.0

## (SDO-500 v2.0)



Kouterbaan 63 1840 Malderen, België +32 (0)52 57 43 02 [info@lockcontrol.be](mailto:info@lockcontrol.be) [www.lockcontrol.be](http://www.lockcontrol.be)



# Context

ATTENTIONS .....	1
Product Features .....	3
Product Contents .....	4
1. Series Model .....	4
2. Accessories .....	4
3. Main unit panel .....	5
4. Dimensions .....	6
Installation Instructions .....	7
1. Track combinations .....	7
2. Push arm combination (Out-swing door installation) .....	9
3. Wiring and preliminary test .....	10
Points And Switches .....	12
1. Points .....	12
2. Door open position learning .....	13
3. Remote learning button(adding new remote control) .....	13
4. Mode functions .....	13
Wiring .....	14
1. External P1 mode point .....	14
2. Master and slave door points .....	15
Application settings .....	16
1. Download the App .....	16
1. Parameters description .....	17
2. Parameters introduction .....	17
Troubleshooting .....	19
Appendix 1. Installation when there is a gap between the wall and the door frame .....	20
Appendix 2. Flip Mode Position If The Track Combination .....	21



# ATTENTIONS



1. Please refer to the figure below to confirm whether the installation environment meets the requirement.

## 【In-swing door】

Pull arm has to be higher than the door leaf

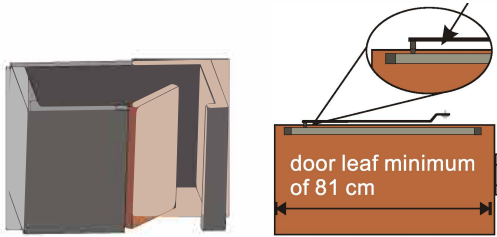

## 【Out-swing door】

Push arm needs to align with the lower edge of the door frame.

Push arm has to be lower than door stop.

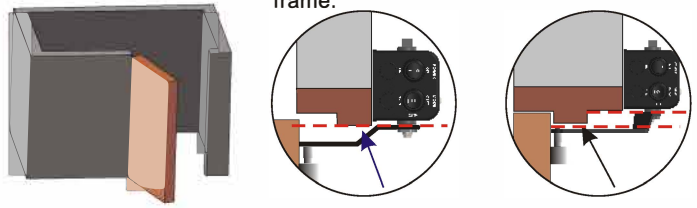

2. The location of the installation must be indoors and close to the hinge.
3. Please push and pull the door leaf to check if the actions are smooth. Improvement must be made if there is resistance or the action is not smooth to avoid abnormal operation of the automatic door operator.
4. Please remove the handle (if any) to avoid pushing or pulling the door handle the act might cause incorrect door positioning.
5. Please remove door bow or ground hinge (if any) of the door leaf.
6. Please install an external collision detector in disabled area or to enhance safety.
7. Please make sure both door frame and door leaf are on the same level when installing on the in-swing door.
8. Please make sure to follow positioning sticker or manual instructions when install in the unit to avoid misplaced door positioning or unable to operate.
9. Please use a spirit level to reduce horizontal errors when installing the unit.

## ■ ENVIRONMENT REQUIREMENTS FOR USING TRACK FOR IN-SWING DOOR

The best installation condition.

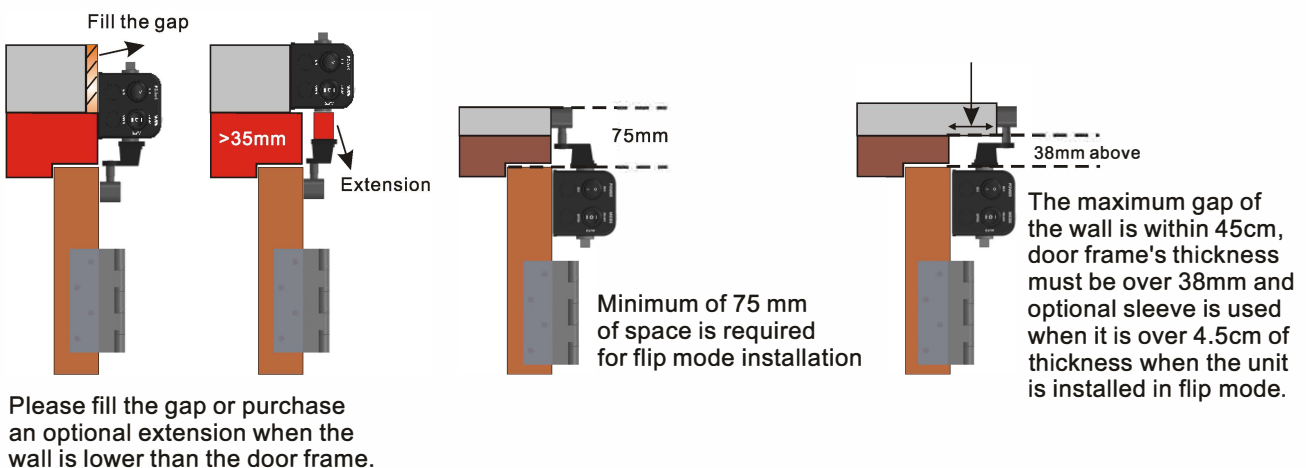
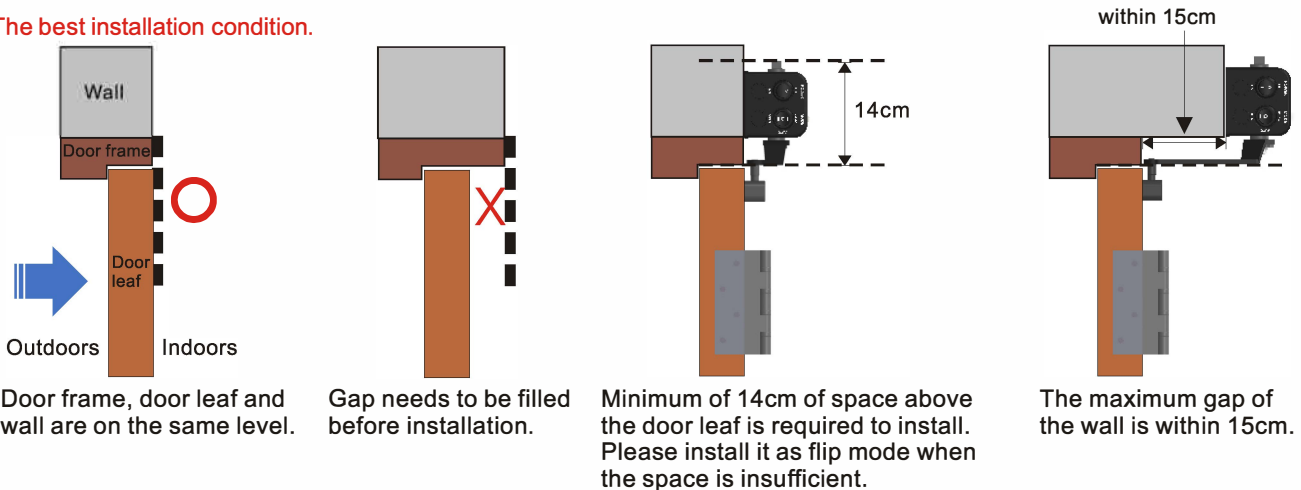

## ■ ENVIRONMENT REQUIREMENTS FOR USING TRACK FOR OUT-SWING DOOR

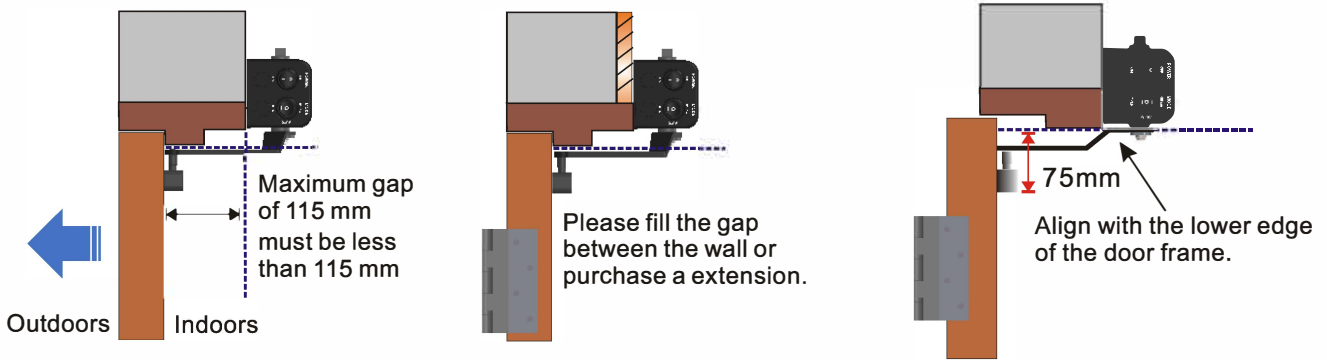

### 【 Flip Mode 】

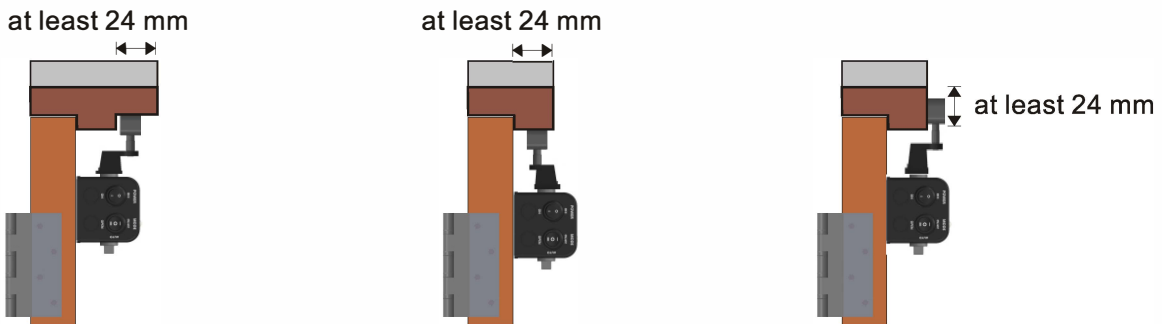

## ■ ENVIRONMENT REQUIREMENT USING DRIVE ARM FOR OUT-SWING DOOR

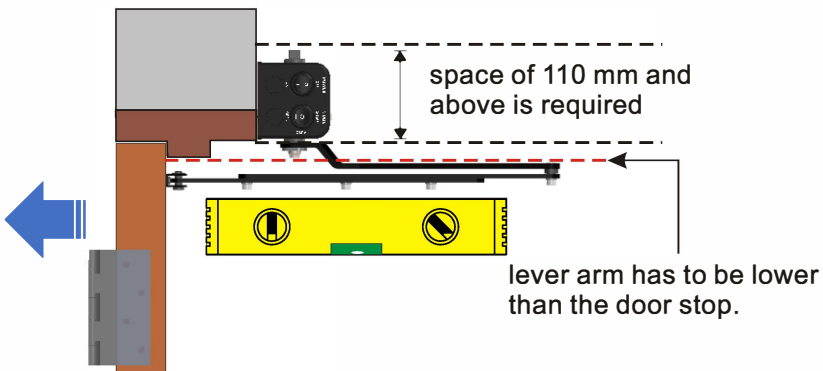

**!** Incorrect position of the tripod may after the door open angle.

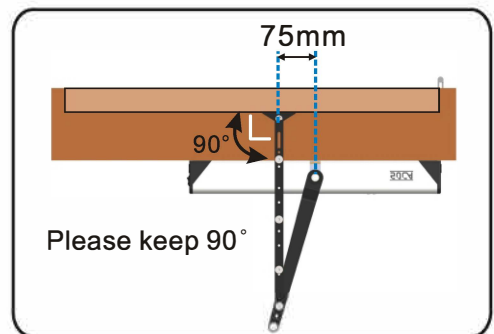

## ■ DIAGRAM OF THE RELATION BETWEEN DOOR LEAF AND DOOR WEIGHT LIMIT

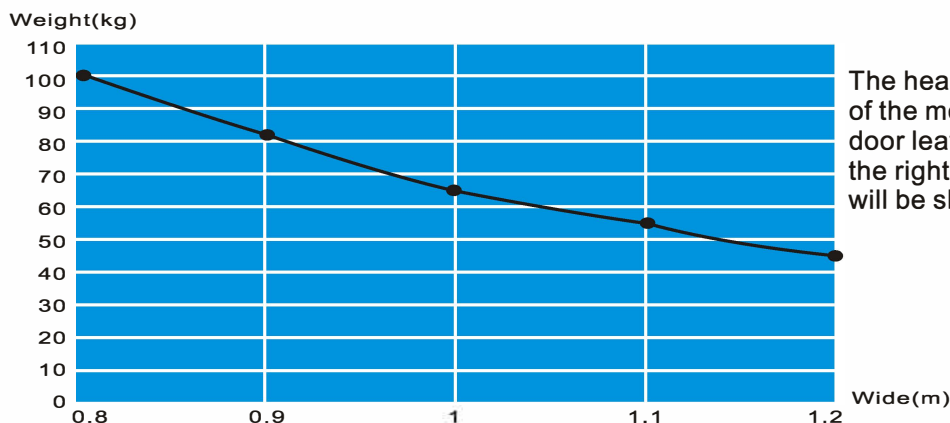

The heavier of the door leaf, the greater of the motion inertia. If the width of the door leaf and door weight are exceeding the right diagram, door opening speed will be slower and unable to stop.



# PRODUCT FEATURES

- Provide automatic self-closing function, without touching the doorknob for accessing move conveniently.
- Built-in Bluetooth, advanced fine-turning settings using APP interface.
- Two types of force arm to select to solve the gap between the door frame and the door leaf within 30cm.
- Automatic position learning and thrust force safety . easy installation without complicated setting procedures.
- It is available to install on door frame or door leaf. Move flexibility of installation for more complicated.
- Optional 2.4G automatic door access control transmitter or 315/433 MHz controller available to purchase to provide long distant door open function.
- Centered bilateral output shaft available for output position to select according to the environment. optional door loop to purchase to protect the external wires.
- Chute lever arm using balls shaft to reduce noise and extend its service life. Patented roller design to allow larger installation error or flatness of door leaf and door frame.
- Safety protection mechanism. The main unit is equipped with built-in proximity protection anti-collision functions. The protection mechanism is activated immediately once it touches an object. Two sets of external proximity protection input points are provided (door open proximity protection point, door close proximity protection point) to achieve a complete safety protection.
- Additional of 1.5 kg of force is added to push open the door when power failure happens and it does not impede escape during emergency.

**Please use a fail-safe electric lock when user needs to use the door arbitrarily under power failure.**

<b>SPECIFICATION</b>	
Power supply	90~264VAC ±15% , 50/60 Hz
Power consumption	72W(3A@DC24V)
Maximum output force	45Nm
Surrounding temperature	-20~60° C
Door width	min. 81cm~ max. 120 cm
Door weight	100 Kg
Opening angle	120 °
Reveal depth	Track set (in-swing door) : 0~15cm Track set (out-swing door) : 0~11.5 cm (maxi of door open angle will be less than 120° when it is exceeding 11.5 cm) Push arm (out-swing door) : 10~30 cm
Input point	Door open points×2 、safty sensor×2 、interlock system
Output point	Electrolock output contacts (NO/NC/COM)/ 0.5A@DC24V
Operating mode	Main unit built-in : always open/ always close (external switch is required)/ one way/ fully automatic
Historical data	5,000 records (available to inquire from App)
Door open time	1~255 sec.
Frequency	315/433MHz(transmitter) / 2.4G (bluetooth)
Status display	Dual-LED×2(action/ communication indicator)
Transmitter capacity	750 transmitters (optional)
Buzzer	Built-in buzzer
Noise exposure	≤55db
Dimensions	532(L)x74.2(W)x70(H) (mm)
Weight	5300g (g.w.)

# PRODUCT CONTENTS



Main unit



Track set



Push arm (or track to select)

- Track set is suitable for most door leaf.
- Optional of push arm to purchase if the gap between both out-swing door's door leaf and door frame is exceeding 11 cm and above.
- Optional of door loop (SSD-50/60) to protect the external wires when the unit is intalled on the door leaf.

## 1. Series Model

SDO-501	Track set, Built-in Bluetooth
SDO-501L	Track set, Built-in Bluetooth , 315MHz remote control included
SDO-501A	Track set, Built-in Bluetooth , 433MHz remote control included
SDO-502	Push arm set, Built-in Bluetooth
SDO-502L	Push arm set, Built-in Bluetooth , 315MHz remote control included
SDO-502A	Push arm set, Built-in Bluetooth , 433MHz remote control included

## 2. Accessories

### Standard

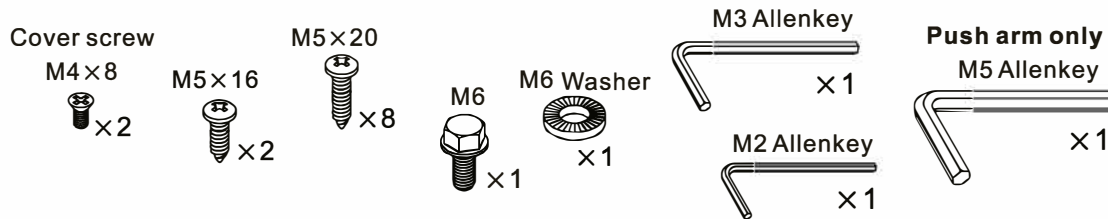

### Optional

#### < Extension >

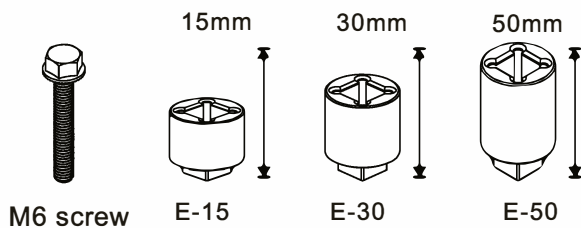

#### < Band Switch >



#### < Door Loop >

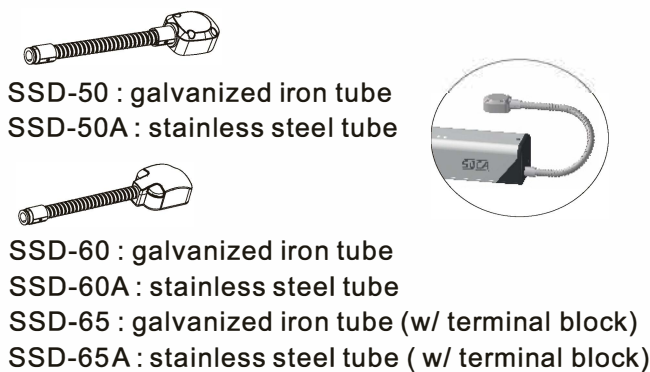

#### < Transmitters >

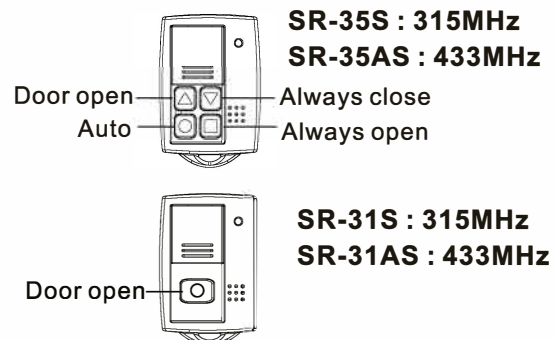

### 3. Main Unit Panel

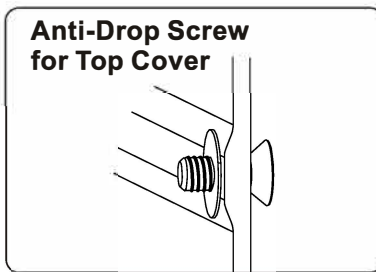
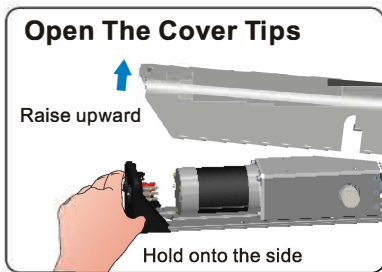
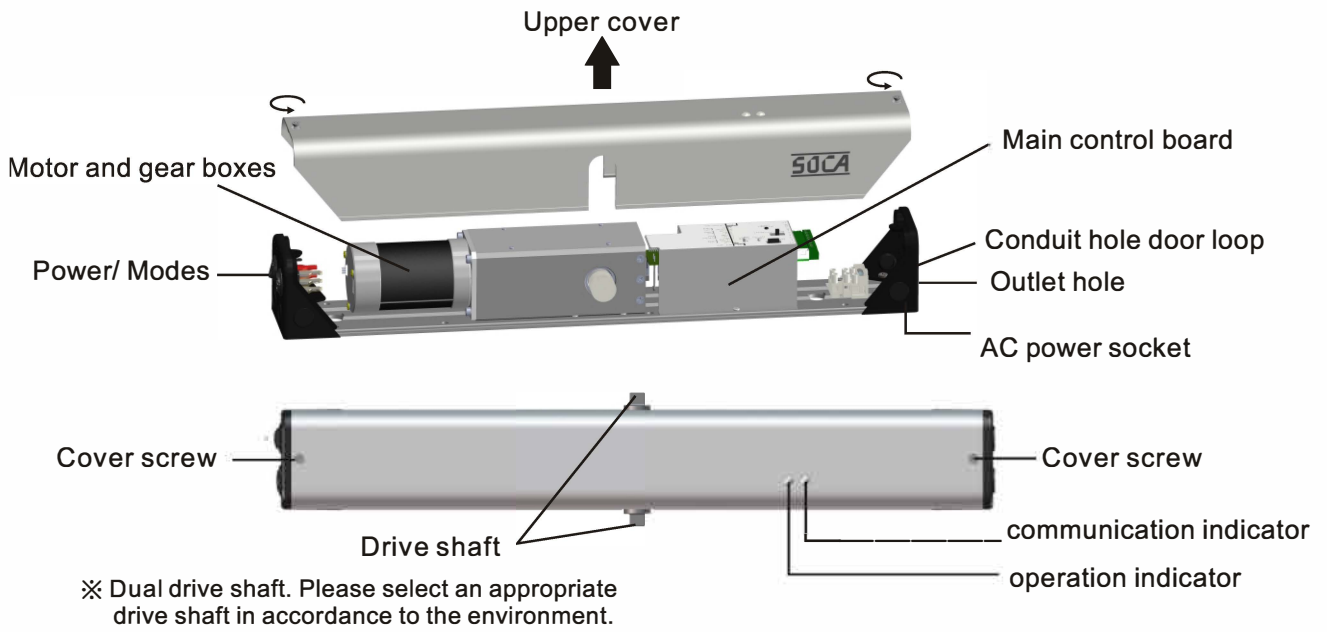

#### ■ Installation of push arm/ track set

Please do not screw it tightly before making sure of the installation position.

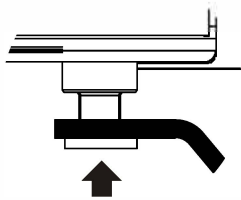

Install the push arm into the drive shaft.

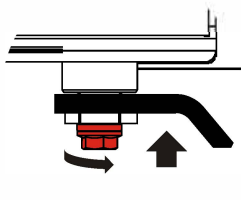

Use a hex bolt to screw both push arm and drive shaft tightly.

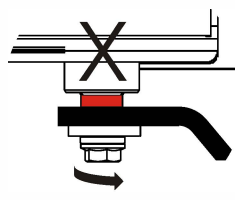

Under normal circumstances, there is no gap between the push arm and the output shaft when in use.

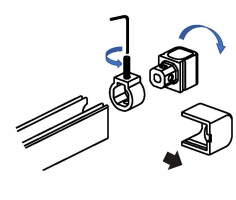

Please adjust the fixed direction of the track according to the environment.

#### ■ Drive shaft application example (change the direction way)

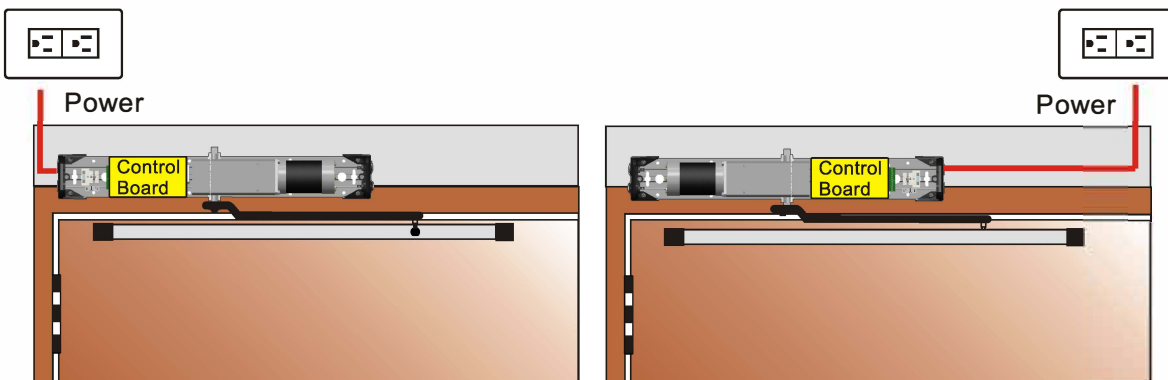

# 4. Dimensions

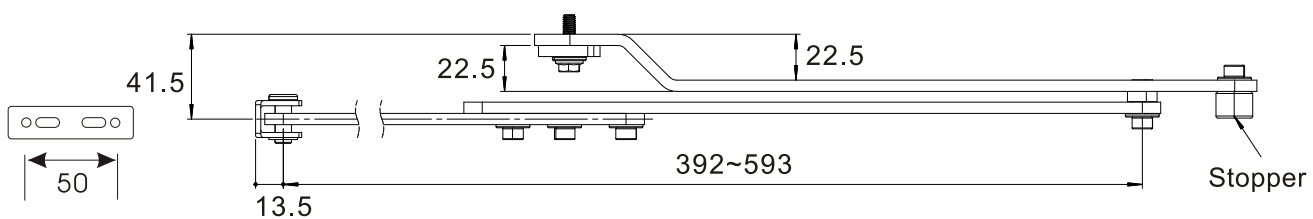
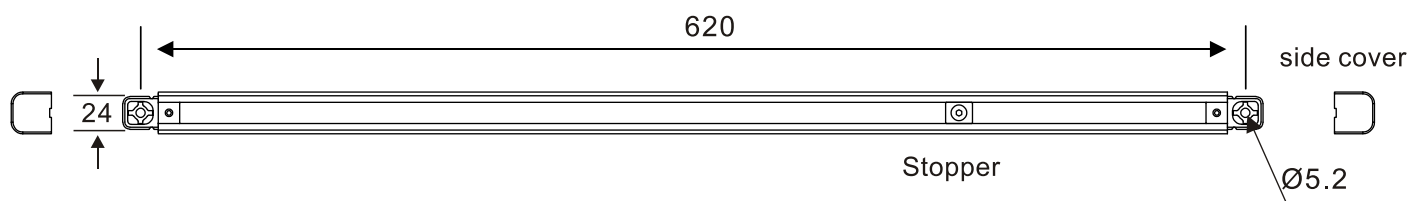
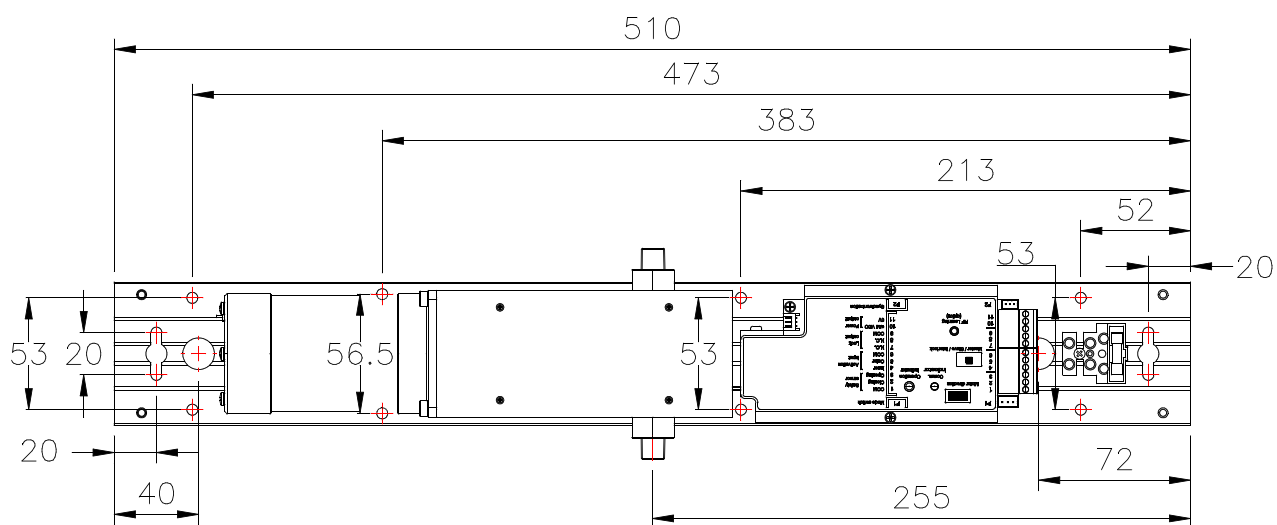
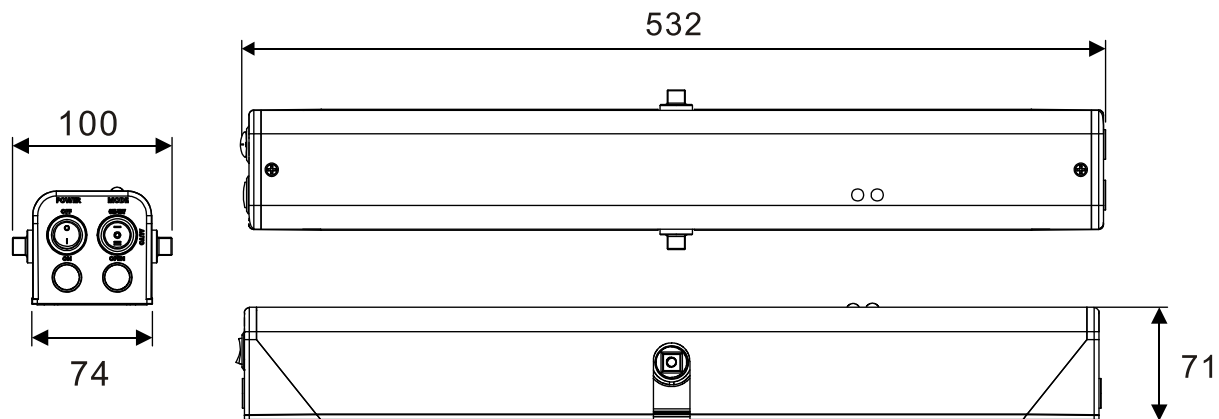

Unit : mm



# INSTALLATION INSTRUCTIONS

(Please refer to the corresponding installation instructions according to the environment)

- ★ Both the wall and the door frame are on the same level is the best installation environment.
- ★ Please fill the gap or refer to page 1 the relevant position to evaluate if the unit is able to install and self-positioning is required when both are not on the same level

## 1. Track Combinations

### [ STEP 1 ] Assembling arm

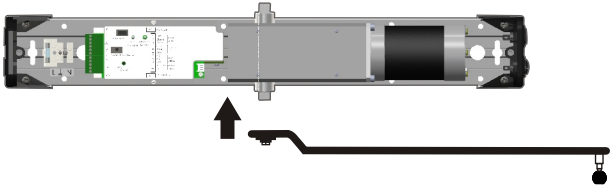

Install the push arm and screw it tight with hex bolt. Please make sure the track position before screwing it tightly as output shaft and push arm have tight fit design which is not easy to dismantle once it is tightly screwed.

### [ STEP 2 ] Confirm main unit position

#### In-swing door installation

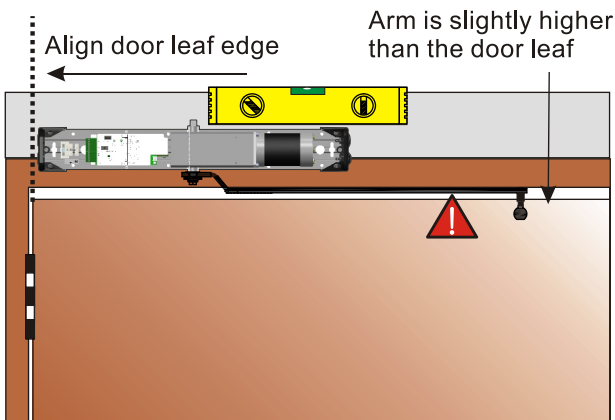

#### Out-swing door installation

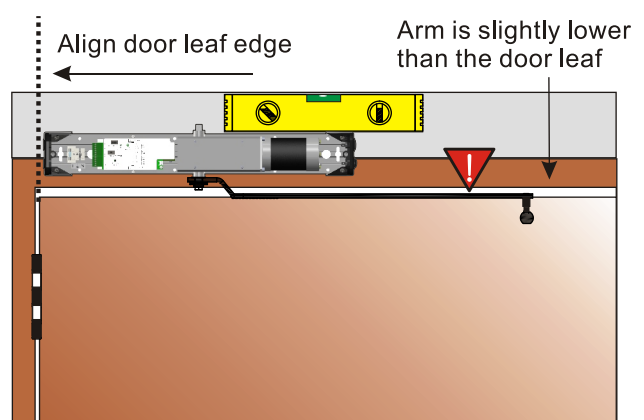

### [ STEP 3 ] Fix the main unit

1. Mark with a tool, locate the oval screw hanging holes on both sides, and then temporarily place the main unit there.
2. Tighten M5×20 screws, reserve 5mm in length for hanging space.
3. hang up the main unit and adjust to the correct position before tightening the screws.

※ use the oval hole to temporarily hang the main unit and fine-tune the error when drilling.

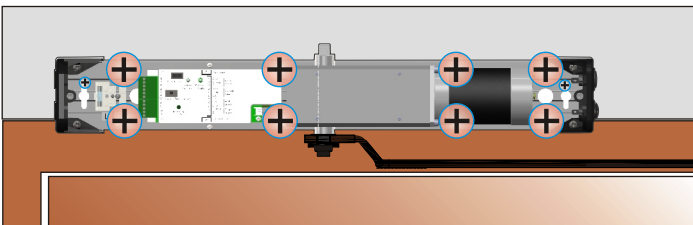
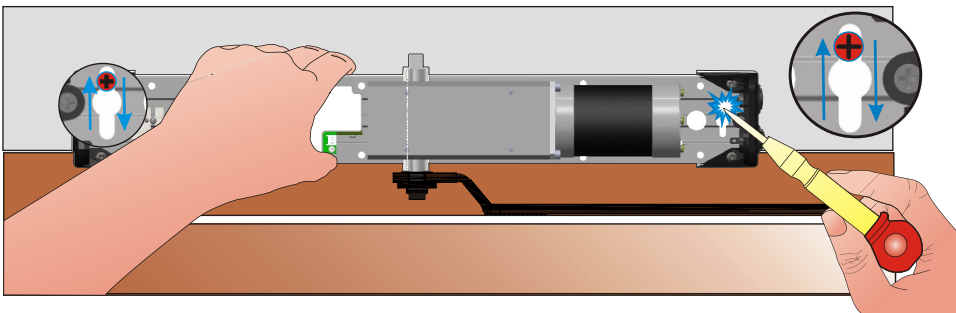

After confirming that the position is correct, locate the position of the eight screws and tightening when to complete the installation of the main unit.

## [ STEP 4 ] Installing track

### In-swing door installation

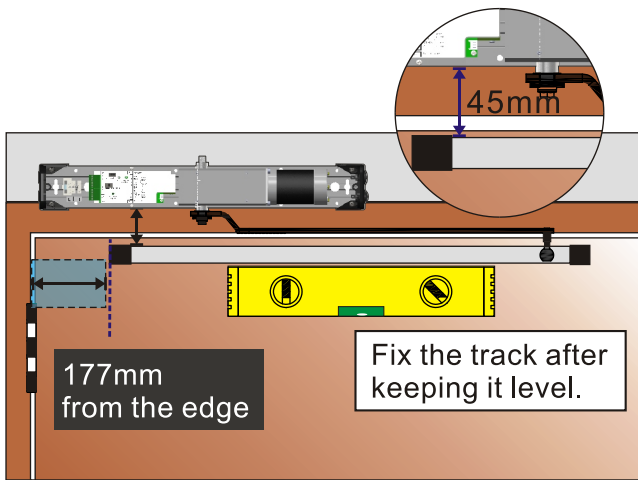

### Out-swing door installation

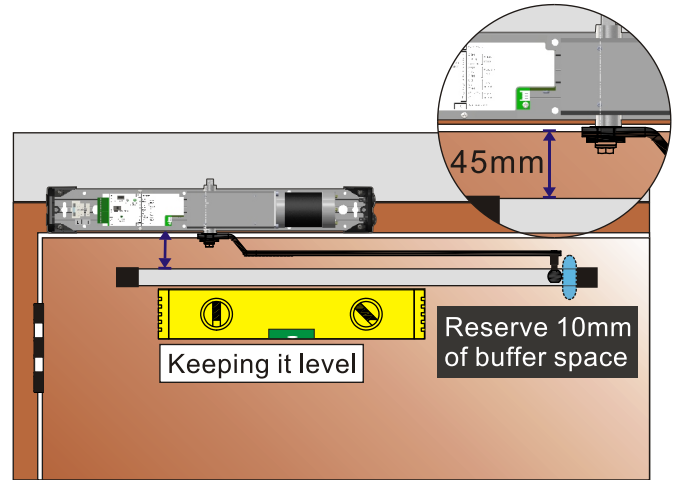

## [ STEP 5 ] Adjust the stopper position

### In-swing door installation

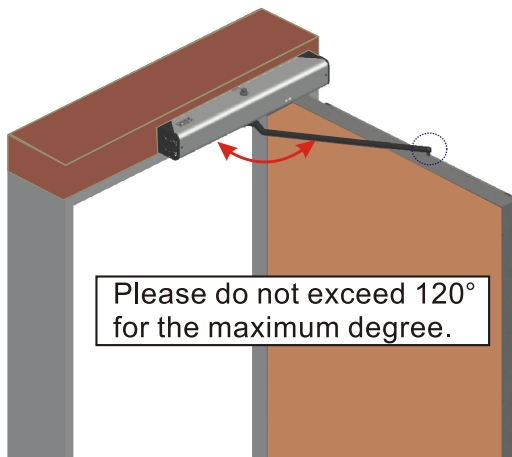

### Out-swing door installation

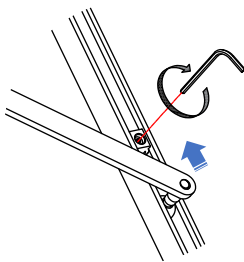
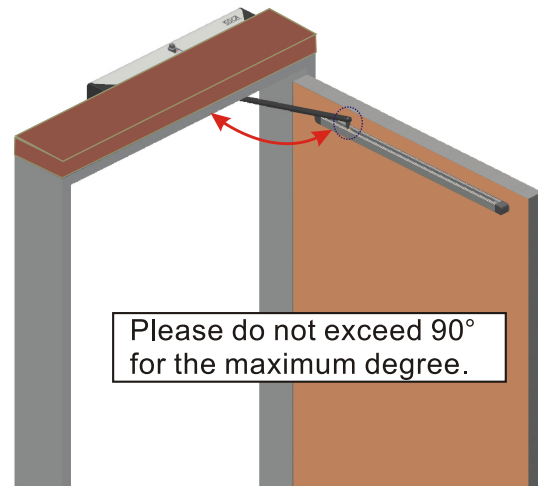

Loosen the stopper screws, push the door manually to the desired maximum position. Use push arm ball to push the stopper to the right position and screw tightly to finish the installation. Stopper is used to limit maximum door open position to avoid hitting on other objects ( such as wall).

## 2. Push Arm Combination (Out-swing Door Installation)

### [ STEP 1 ] Assembling arm

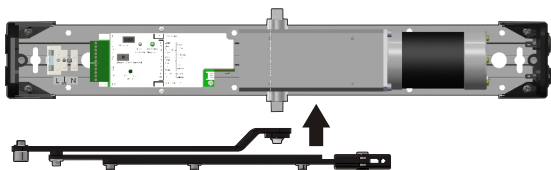

Since both the output shaft and the arm have a tight fit design, it is not easy to disassemble after tightening the screws. Please confirm if it is necessary to install an extension sleeve and then tighten the HEX bolt.

### [ STEP 2 ] Fixing the main unit

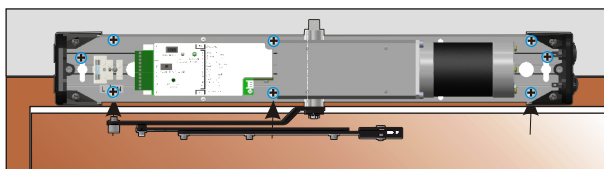

Refer to page 7 for the steps.

### [ STEP 3 ] Find the position to install the tripod

- ★ If the position of the tripod is incorrect, it will affect the opening angle of the door.
- Please loosen the screws to adjust the push arm. Adjust and screw the telescopic push arm tightly at 90 degrees to the door leaf .
- Adjust the arm to a horizontal position which is about 39mm from the main unit and then fix the tripod.

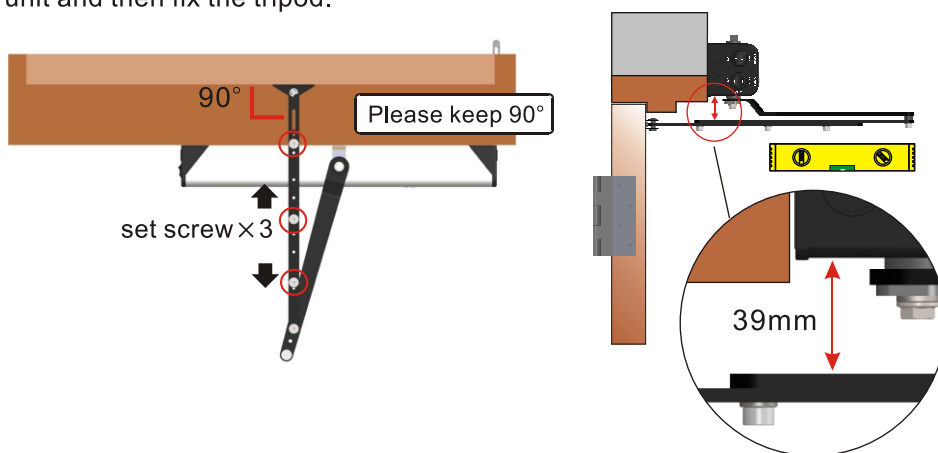

### [ STEP 4 ] Complete the installation

- Push the door leaf to check if it is smooth and can be able to reach the desired opening angle.
- To avoid pushing the door leaf intentionally that exceeds the maximum angle, user can install a door stopper.

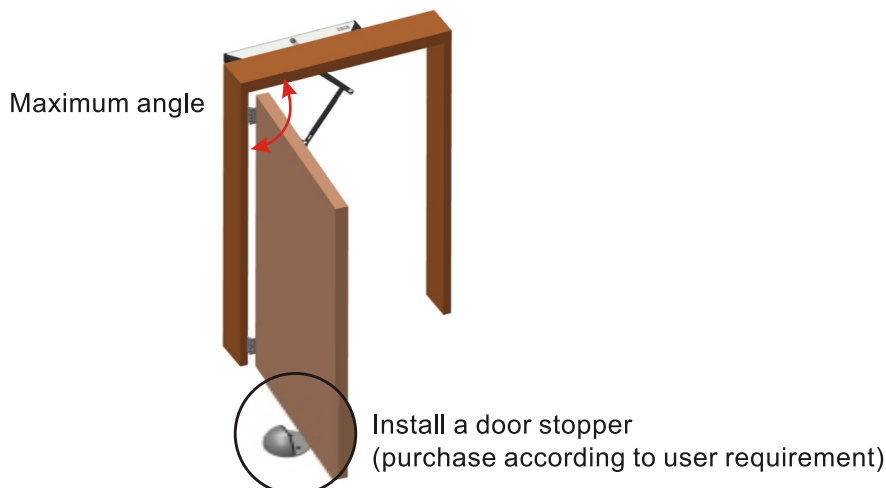

### 3. Wiring And Preliminary Test

The newly installed door opener can perform automatic door position detection through the switching mode (no external equipment is required). Please follow the following steps to perform automatic door position detection to confirm the unit is able to function. User can connect other detection equipment such as door open push button or anti-pinch infrared detection when opening and closing door positions are correct.

※ Preliminary test to conform whether the door opener is able to function and door position is correct. User can adjust the speed of the buffer angle on the APP.

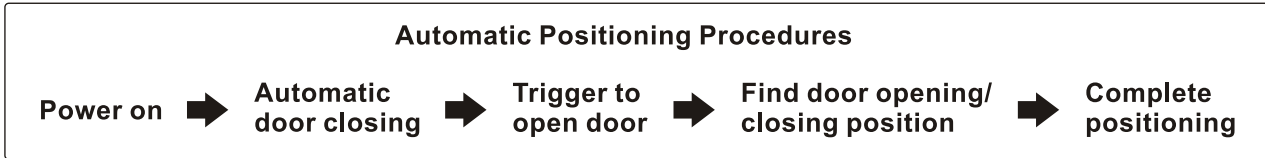

#### { STEP 1 } Power on to find the origin of the door position

Power off

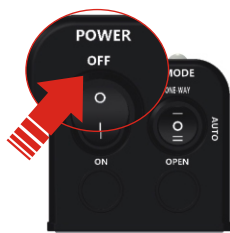

Please make sure the power button is OFF.



Connect to AC power 90~264VAC

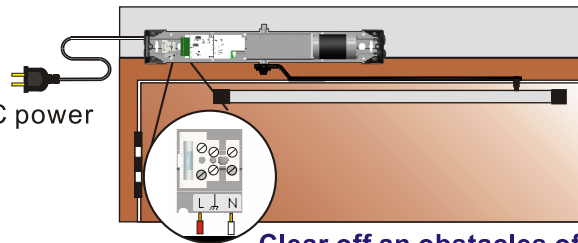

Clear off an obstacles of the door leaf operation area.

Power on



Turn on the power.  
Beep sound once to boot.



Closing direction    Opening direction

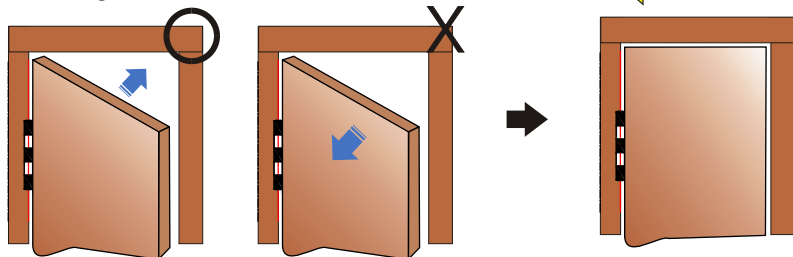

Door leaf moves slowly toward the closing direction to find its original closing point.

1 beep sound. To indicate original closing point is found.

#### Direction of the motors

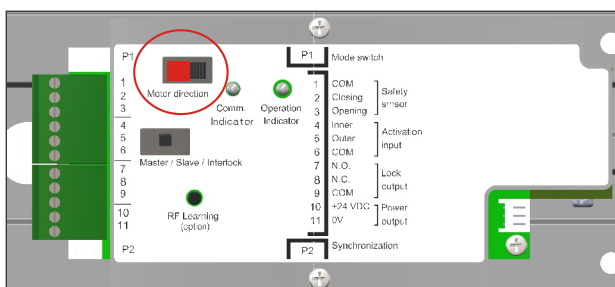

Please turn off the power and adjust the motor switch to change the direction when door open direction is incorrect during the initial power on.

**[ STEP 2 ] Trigger to open door to find the anchor point of door opening and closing.**

Please turn off the power, clear off all execute steps 2 again when obstacles are found to cause incorrect position during the learning process.

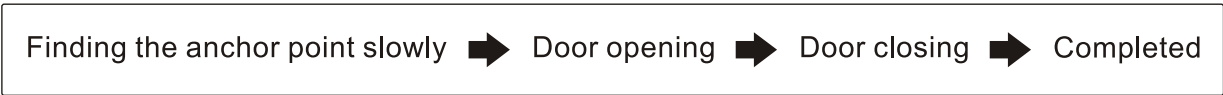

3 beep sounds



Switch the mode as OPEN

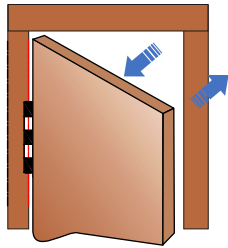

Door opening slowly and Door closing once to learn position point

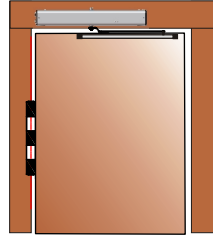

Back to door closing position

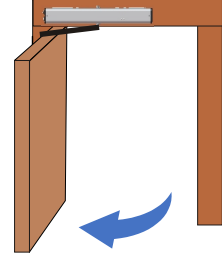

Automatic door opening to setting position

**[ STEP 3 ] Switch to automatic mode after testing.**

3 beep sounds



Switch the mode as AUTO

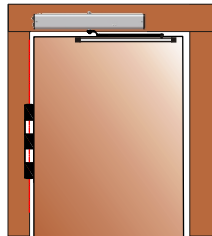

Back to door closing position

Basic installation is completed and referred to page 12 , continue to configure other input points such as door open point.

## Troubleshooting

**Q :** The opening and closing of the door is not smooth, unable to reach the position or stop halfway when the automatic learning of door position is operating.

1. Turn the power off. Manually check the door leaf if there is any resistance that affects the rotation.
2. Check and make sure the position of the main unit and arm/ track are in correct position. Check and make sure track or arm is on level.
3. Refer to P2 check list to see if the maximum weight and width of the door are exceeded.

**Q :** Then movement of door opening or closing is very slow or stopped when door position learning is ended.

1. Turn the power off. Check if the door leaf is unable to move smoothly.
2. Check if the parameter of arm system on the APP is correct.
3. The weight or width of the door is too close to the maximum value (refer to the list on P2) when the door leaf is moving very slowly as it enters deceleration zone. Adjust and increase the buffer speed of the parameter and reopen the door again.

# POINTS AND SWITCHES

## 1. Points

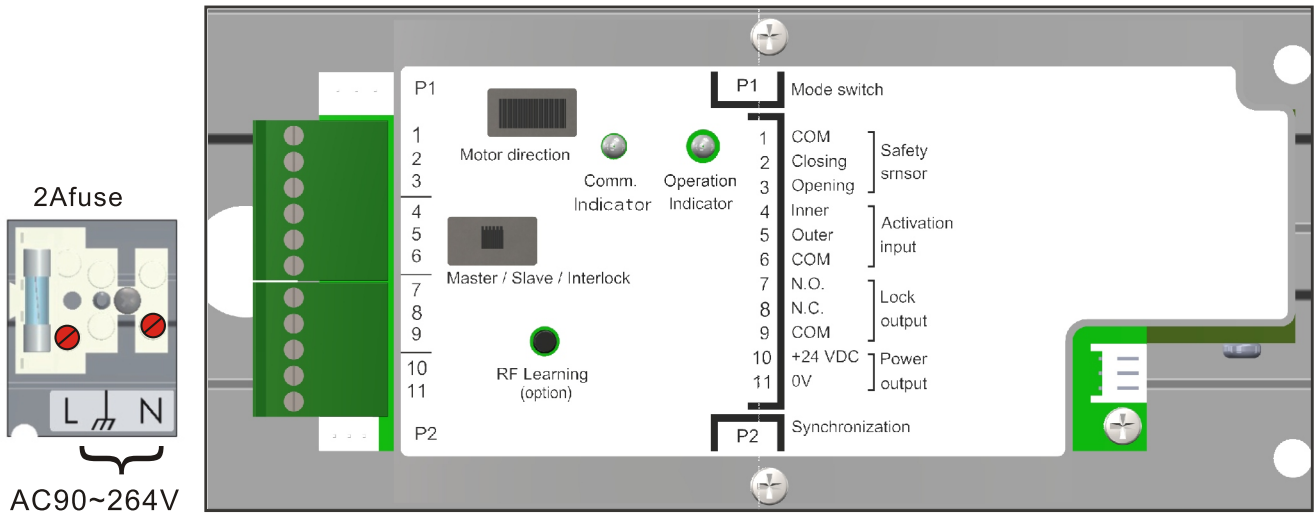

Points		
<b>1</b>	C O M	Infrared detector point
<b>2</b>	Closing	Infrared input point. Door closing detector.
<b>3</b>	Opening	Infrared input point. Door opening detector. Door leaf stops moving once it is detected.
<b>4</b>	Inner	Exit button point. Door leaf opens when it is triggered.
<b>5</b>	Outer	Enter button point. Door leaf opens when it is triggered.
<b>6</b>	C O M	COM point for both enter and exit buttons.
<b>7</b>	N . O .	Electric Lock RELAY N.O. Point
<b>8</b>	N . C .	Electric Lock RELAY N.C. Point
<b>9</b>	C O M	COM point for electric lock RELAY point (2A@24VDC)
<b>10</b>	+ 24 VDC	Positive power supply output (+24V) Max:0.5A
<b>11</b>	0V	Negative power supply output (0V)

## 2. Door Open Position Learning

Each time the main unit is repowered, it will automatically learn the opening position when the first entry and exit trigger the door opening input point.

1. After it is re-powered, the unit executes low-speed door closing action in order to find door closing location point and continues its closing action.
2. Door opening input point is triggered by the first entry and exit. After 3 beep sounds, door opener executes slow-speed door closing action. When finding door closing location point is completed, the unit starts to operate after another entry and exit.

## 3. Remote Learning Button (Adding New Remote Control)

- Press the remote learning button for 3 seconds and 2 beep sounds to enter remote learning mode.
- System indicator light flashes once every second. When pressing any button on the remote control, one long beep sound to indicate the completion of entering.
- When pressing the remote control, 6 quick flashes of system indicator light indicates the card number is registered in the unit.
- After the input, press the learning button for 3 seconds. One beep sound to exit remote learning.
- ※ The main unit automatically exits setting mode when there is no action after 30 sec. .

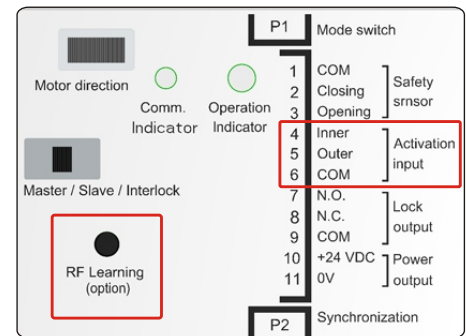

## 4. Mode Functions

### ● Single/ One-way mode

Suitable for customers are only allowed to exit during the closing hours. Use of remote control or access control unit for the access of the employees.

Active	Exit point to open door
Inactive	Enter point to open door
Active	Remote control to open door

### ● Automatic mode (AUTO)

Suitable for all automatic assess use.

Active	Exit point to open door
Active	Enter point to open door
Active	Remote control to open door

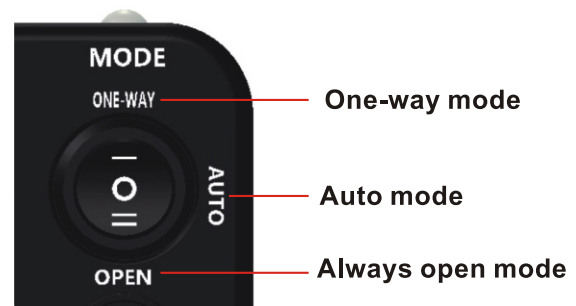

### ● Always open mode

Suitable for temporary door open for period of time (moving goods).  
 ※ Door leaf remains opening state, all closing function is not available.

### ● Always close mode

※ External band switch is needed for this mode.

Inactive	Exit point to open door
Inactive	Enter point to open door
Active	Remote control to open door

# WIRING

## 1. External P1 mode point

Input point selection	Mode	Side cover 3-band switch code	Indicator light
Not connecting to any points	(Fully Automatic)	0	Green
Connect 1&2 points	(Always Open)		Green
Connect 3&2 points	(One way)		Red
Connect 1&2&3 points	(Always Close)		Red

※ optional external band switch (SW-52) to use.

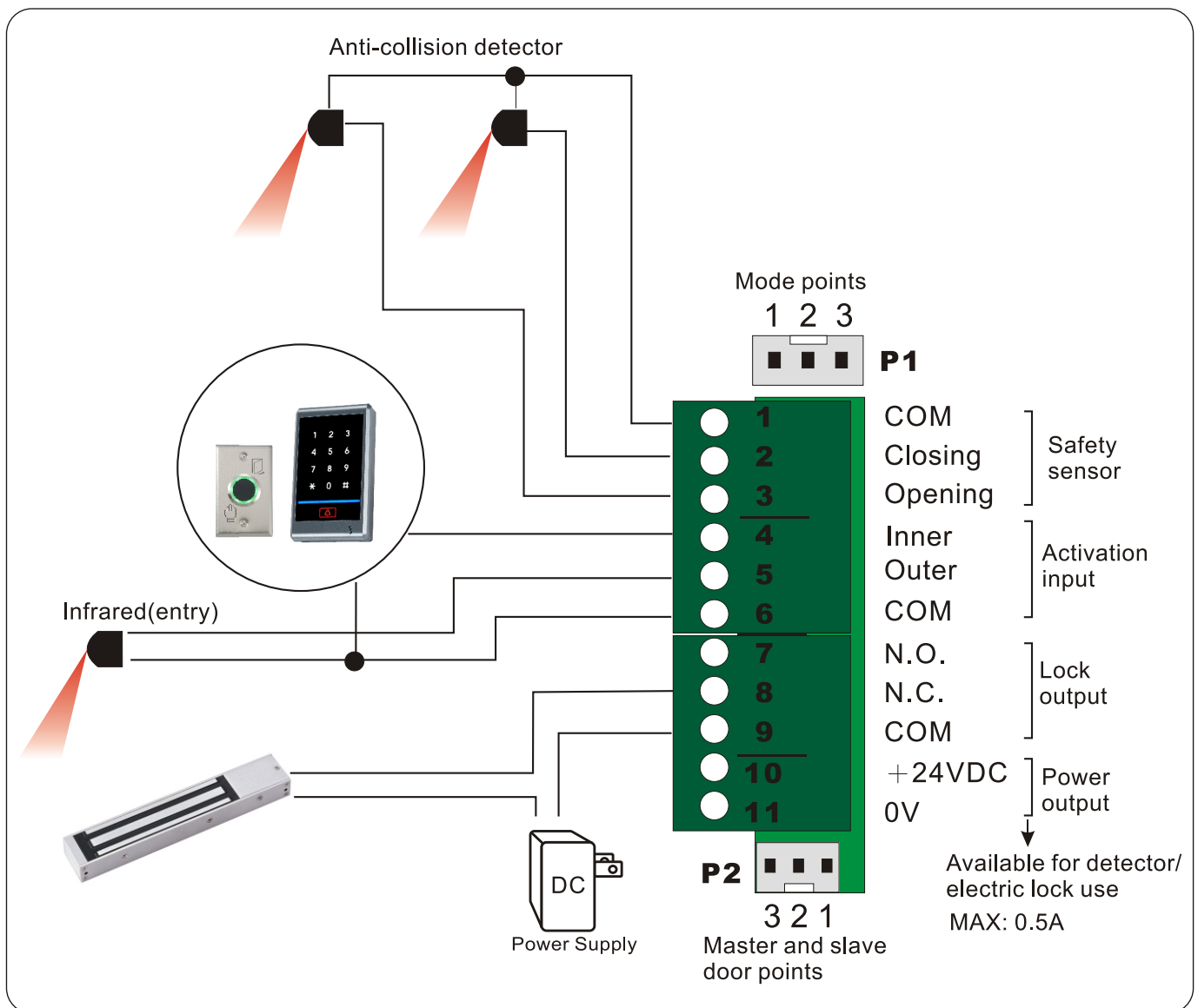

※ It is suggested to connect 4&6 points when connects with access control unit. Therefore, the access control unit is able to control the operator to open door under [one way] mode.



## 2. Master And Slave Door Points

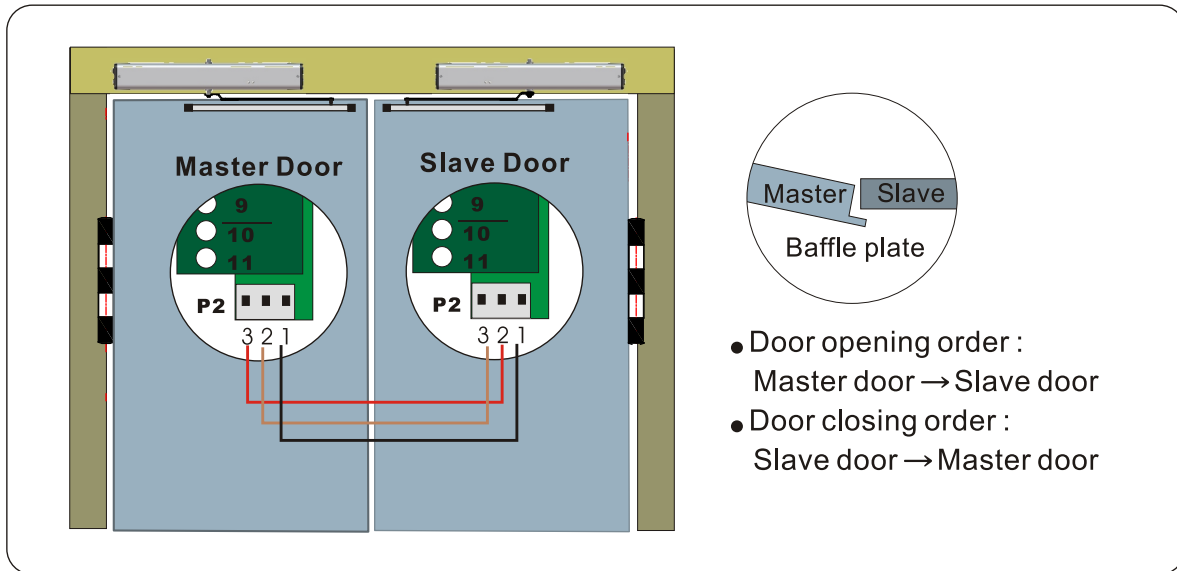

### ■ Master And Slave Doors Function :

Apply to the master door with baffle plate or door opening order. If the doors do not require opening order, connect door open points together to open both door simultaneously.

### ■ The Learning Process If Master/Slave Door Positioning :

- Please make sure both door leaves wires are connected before power on when the hardware is installed.
- Confirm both Master's /Slave's dip switches position.
- Push the Master/Slave doors manually to the maximum angle.
- First, power the slave door on to execute slow-speed door closing to the location point.  
Add a new door opener unit as Slave Door on APP.
- Then, power the Master door on to execute slow-speed door closing to the location point.  
Add a new door opener unit as Master Door on APP.
- Master/Slave doors execute door open positioning learning separately :
  1. Switch to Always Open mode (or trigger door open point), automatic door open position learning :  
Position Master Door first → then the same method to position Slave Door.
  2. Switch to Automatic mode when door open positioning is completed.
- Positioning learning is completed.

### ■ ATTENTION :

- Need to operate with APP settings
- Please use APP to adjust main unit's advanced parameter.
- Please adjust the parameters for the Master door's door opener (speed, buffer angle, and etc.), then copy and paste the parameters to the slave door's door opener.
- All functions must be controlled by the master door when the unit is using APP to set on the slave door.

# APPLICATION SETTINGS

## 1. Download the APP

The unit uses default parameters (speed, baffle angle) to operate after the installation is completed. Download the APP for advanced setting when the door opening speed or baffle angle does not meet the requirements.

※ Search BDM Tool or scan the QRCode below to download the APP.



IOS



Android

## ■ Pair the device

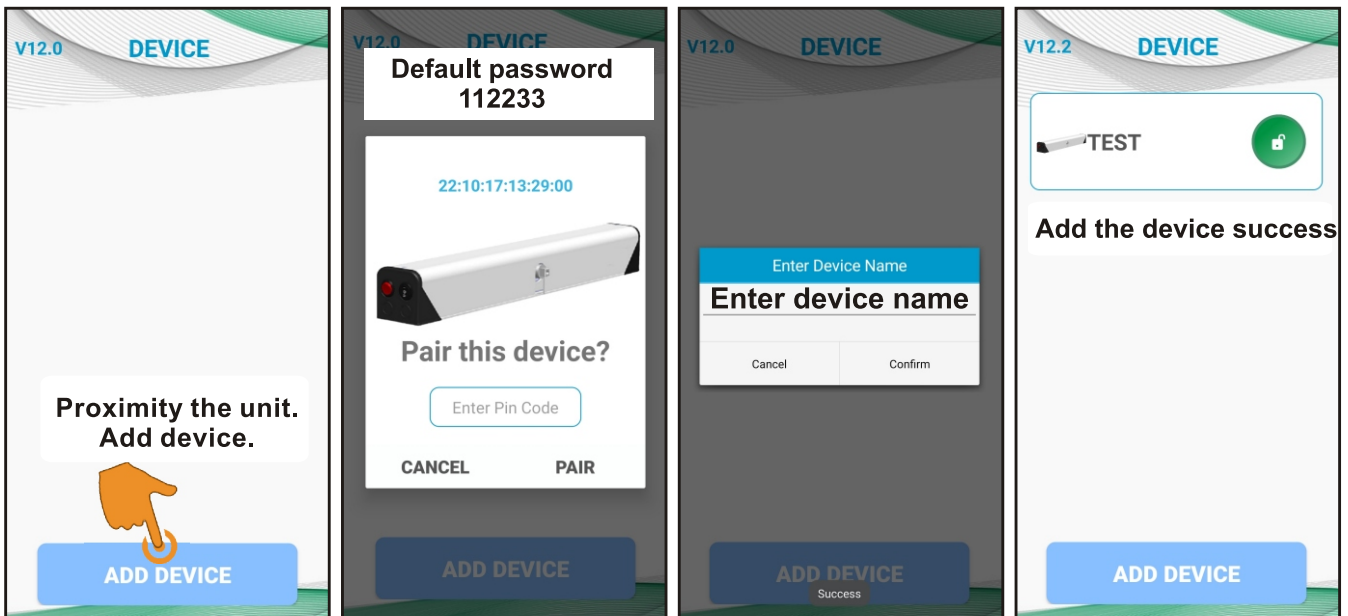

## ■ Parameter setting

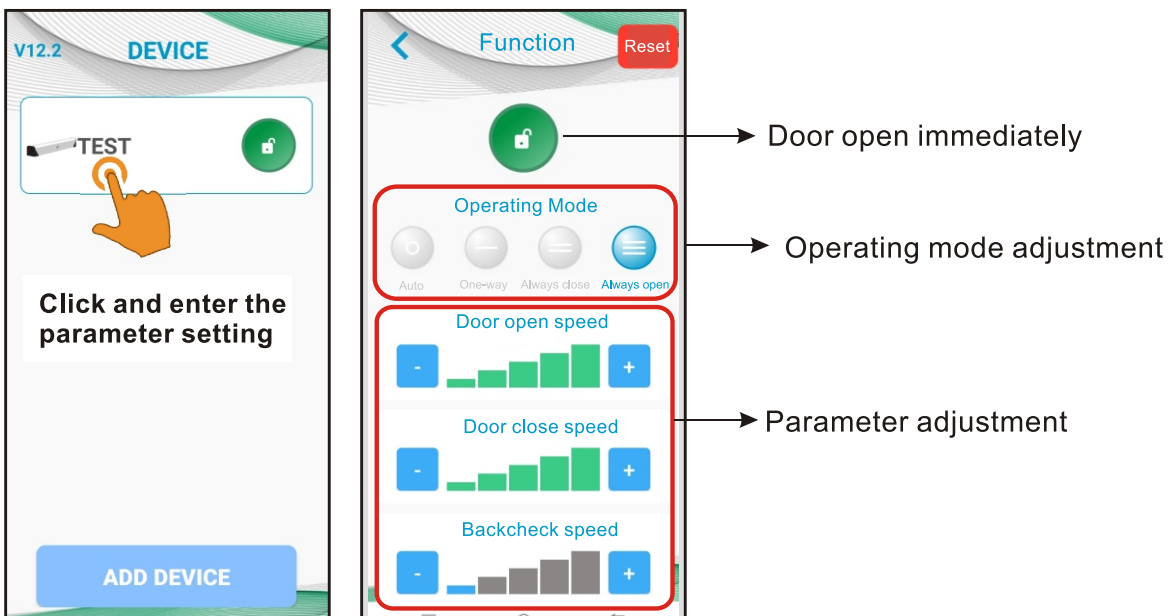

## 2. Parameters Description

Parameters	Description
Door open holding time	The length of holding time (1~255s) when the door leaf is at the open position .
Door open speed	Door open speed (1~5 speed)
Door close speed	Door close speed (1~5 speed)
Backcheck speed	Door open backcheck speed (1~5 speed)
Latching speed	Door close latching speed (1~5 speed)
Backcheck angle	Door open backcheck angle(1~5 level)
Latching angle	Door close latching angle(1~5 level)
Anti-collision force	Sensitivity level (1~5 ) to judge obstacles when the door leaf is moving.
Door closing force	Door closing force (applicable to higher wind pressure area) (1~5 level) when the door leaf is at the door closing positioning point.
Door open reversal force	Force (1~5 level) needed to reverse in order to disengage lock bolt when incorrect door positioning happened.
Door open reversal time	Time (0~0.9s) needed to reverse in order to disengage lock bolt when incorrect door positioning happened.
Buzzer indicator	selection of all actions reminder or only before door closing reminders
Buzzer	Selection of on or off
Transmitter registration	Learning registration
Arm system	Selection of arm push or track
Wind resistance/ push and go	Selection of door closing torque as force is added to close the door leaf tightly when the door leaf is back to its original point. Selection of push open door manually to help open the door when the door leaf is back to its original point. Push and go mode and wind-resistance mode cannot be selected at the same time.
Door position memory	This feature permanently records the door's open and close positions. After a power outage, the door position learning process will not need to be repeated. Note: If the door position is abnormal, please open the app and re-run the door position learning process.
User list	Card number data of remote control or 2.4 Ghz
Historical record	Records of card number access record and action record of the unit
Door open learning	Door open positioning learning directly from the APP.

### NOTICE :

If you enable the door position memory function, you will need to re-learn the door positioning in the following situations:

- The door closer is installed in a different location or the installation position is changed.
- The arm system of the door closer is modified.
- The width or weight of the door being controlled by the door closer changes.

Note: If you do not re-learn the positioning after making any of the above changes, it may result in abnormal door opening angles and buffer angles, which could cause the door to collide with the positioning point.

### 3. Parameters Introduction

#### Parameters

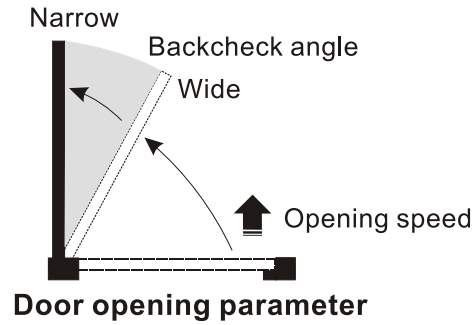
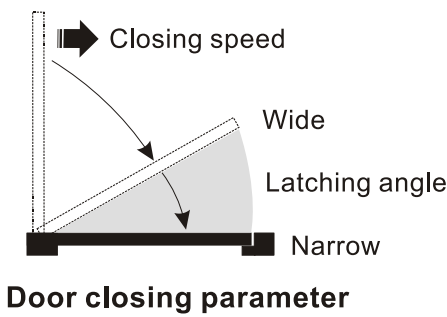

#### Wind Resistance

- Adjust closing force to higher when strong wind pressure causes door leaf to open.
- Adjust to wind resistance mode to activate door closing force.
- Install an electric lock to lock the door tightly when both wind resistance and manual functions are activated.
- In Push and go mode, a certain amount of force must be applied to push the door open about 5-10 degrees, and the door will automatically open to its position for automatic closing.

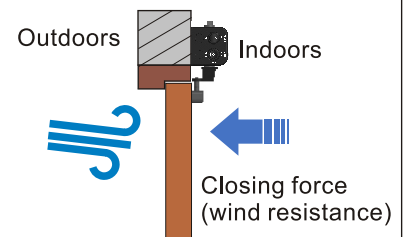
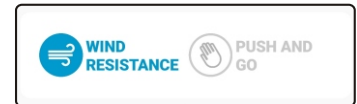

#### Anti-collision

##### Anti-collision function

- Door leaf stops moving with error sounds when collision happened during door opening, door will automatically closes at the original position.
- Door leaf is back to its door open positioning point with error sounds when collision happened during closing. Door leaf activates door closing action again after door opening countdown time is completed.

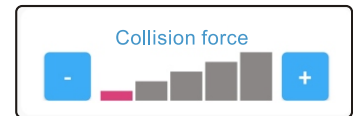

- ※ When 5 continuous times of proximity protection is triggered, automatic door closer gives off continuous error sound and stops all actions. If then goes back to re-execute door positioning learning until any door opening function is activated.

#### Reversal Time

Door opening action sequence

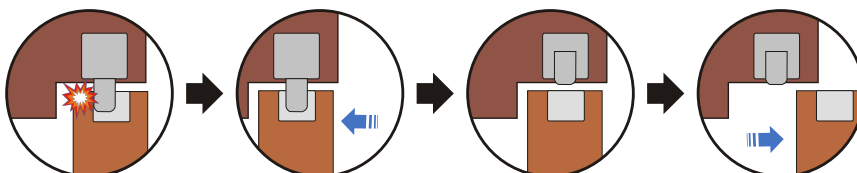

Stuck when opening

Push forward

Unlock

Door open

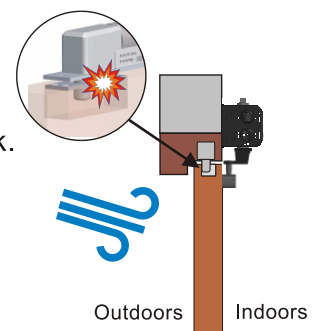

##### Door opening reversal time :

Reversal action before door opening to unlock deadbolt lock or strike lock.

- ※ It is suggested to use electromagnet lock as lock bolt of deadbolt lock or strike lock might be stuck and unable to unlock when wind pressure is high. Door open reversal function helps to solve the problem when user is using deadbolt lock or strike lock.

# TROUBLESHOOTING

## 1. Door leaf is moving too fast and hit the door frame or the wall when opening or closing.

Adjust the buffer angle parameter to increase the buffer angle (wider angle to enter deceleration zone faster). Adjust to lower door opening or closing speed if the incident occurs again.

## 2. Operation of the door leaf becomes slower occasionally.

The main unit is under positioning learning process. It happens when the power is turned back on after an interruption of power supply or human factors that cause abnormal positioning.

## 3. Adjusting wind resistance function.

Door close positioning point might be affected by the strong wind that cause door to open. It is suggested to activate wind resistance function and adjust its Door closing force setting value in accordance to the wind pressure.

✗ Door leaf is unable to reach its positioning point when it is affected by the wind during the operation. Increase the speed of the door opening and closing speed and reduce the door opening and closing's buffer angle so that the door leaf is able to move forward faster and slower to the deceleration area in order to against the wind.

## 4. Power disconnection of automatic door closer by itself.

- ① Check if the power supply of DC24V output point is exceeding 0.5A.
- ② The unit disconnects its power supply when the door is pushed manually by force when it is being set under automatic mode instead of manual mode. Turn on the power to start the unit again.

## 5. "Device is busy" appears on the screen while using a smart phone to perform bluetooth management.

It is unable to perform bluetooth management when the door leaf is in operation. Please wait until the door leaf is back to its door close positioning point to perform bluetooth management.

## 6. Sudden abnormal positioning of the main unit.

- ① Turn off the power. Check if there are any obstacles around the door leaf or the door leaf is stuck.
- ② Turn the power back on and execute door open positioning learning.

## 7. Obstacles behind the door leaf while door open learning is in progress.

Learning angle error will occur that might cause abnormal angle and speed of door opening and closing if there are obstacles while learning is in progress. The following 2 methods are suggested to reinitiate door positioning learning :

- ① turn off the power and clear off the obstacles. Turn the power back on and wait for its door closing positioning point (original point) before triggering any door opening function (exit, enter, remote control and etc) to reinitiate door positioning learning.
- ② Use of APP (door opening learning function) to reinitiate door positioning point.

# APPENDIX 1.

## INSTALLATION WHEN THERE IS A GAP BETWEEN THE WALL AND THE DOOR FRAME.

- Please be aware of the following restrictions when there is a gap between the wall and the door frame during installation.
- Both door frame and door leaf must be at the same level or the door leaf must be higher than the door frame.
- Maximum of 115mm of gap is allowed.

### 1. Track Combination Installation Method (Suitable For In-swing Door)

■ Installation Front View Diagram

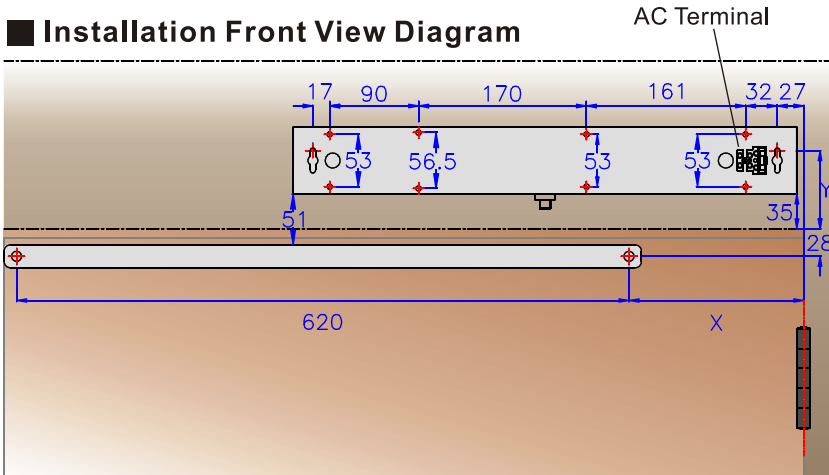

■ Installation Side View Diagram

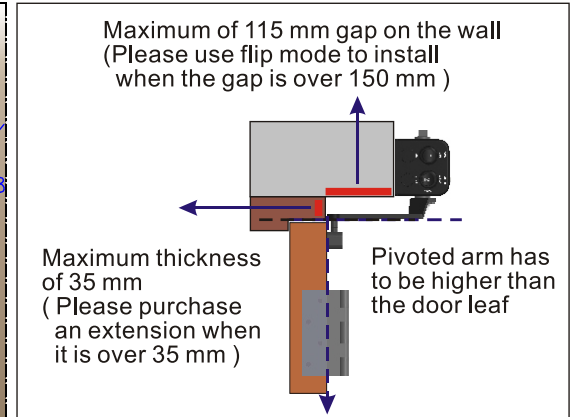

		Unit : mm		Unit : mm	
Extension		Y	Reveal	X	
	0	79	0	177	
E-15	15	94	50	177	
E-30	30	109	100	177	
E-50	50	129	150	177	

### 2. Track Combination Installation Method (Suitable For Out-swing Door)

■ Installation Front View Diagram

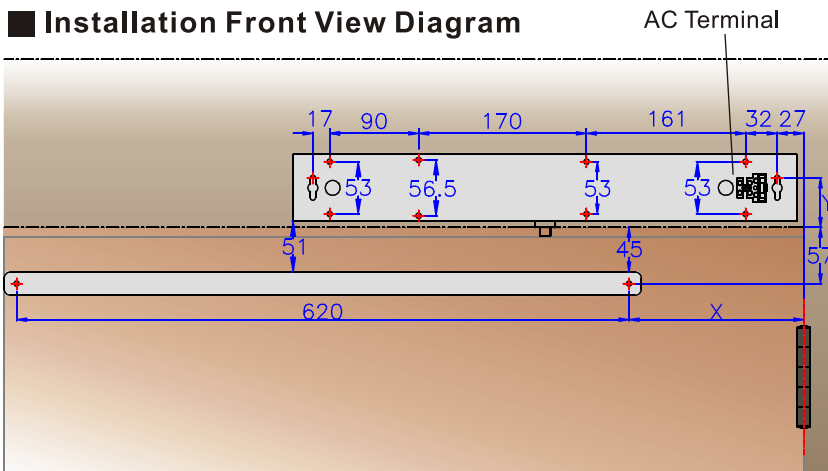

■ Installation Side View Diagram

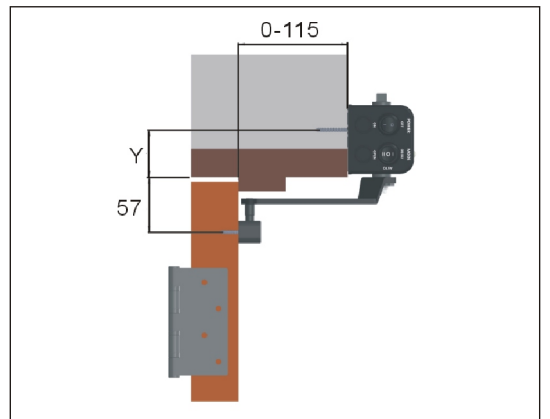

		Unit : mm		Unit : mm	
Extension		Y	Reveal	X	
	0	50	0	150	
E-15	15	65	50	150	
E-30	30	80	100	120	
E-50	50	100	150	100	

## APPENDIX 2.

### FLIP MODE POSITION IF THE TRACK COMBINATION

#### 1. Out-swing Door Flip Mode Method (Installation Position : Door Leaf)

##### ■ Installation Front View Diagram

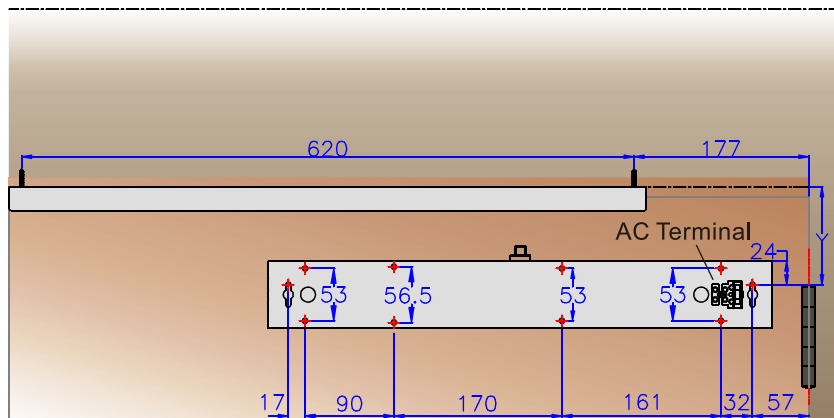

Unit : mm		
Extension	Y	
	0	99
E-15	15	114
E-30	30	129
E-50	50	149

##### ■ Installation Side View Diagram

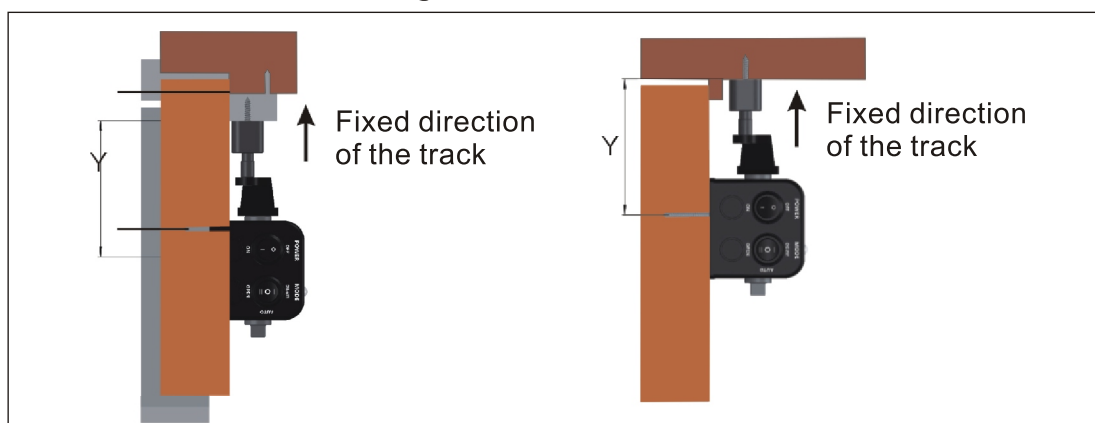

#### 2. Out-swing Door Flip Mode Method (Installation Position : Door Leaf)

##### ■ Installation Front View Diagram

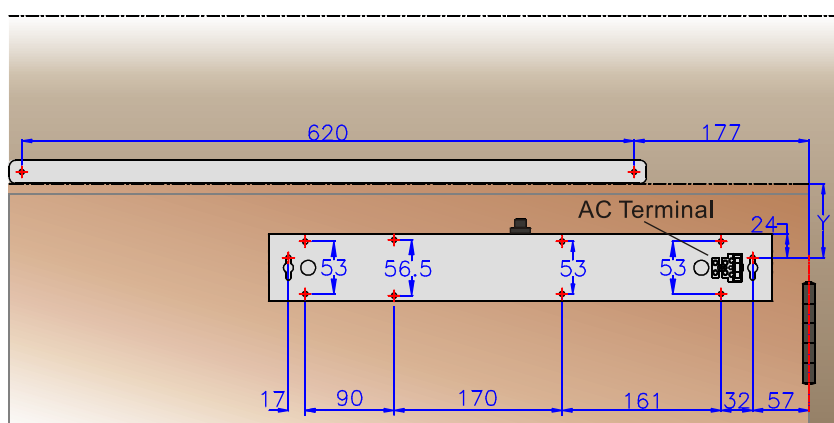

Unit : mm		
Extension	Y	
	0	75
E-15	15	90
E-30	30	105
E-50	50	125

##### ■ Installation Side View Diagram

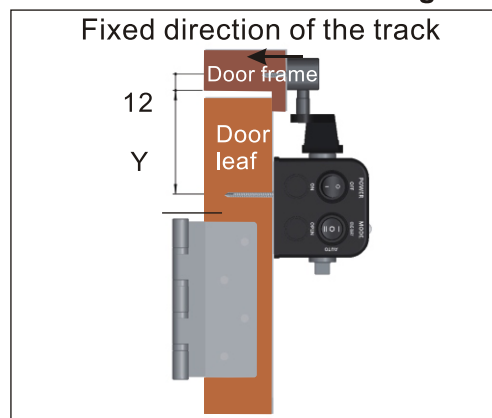

### 3. In-swing Door Flip Mode Method

#### ■ Installation Front View Diagram

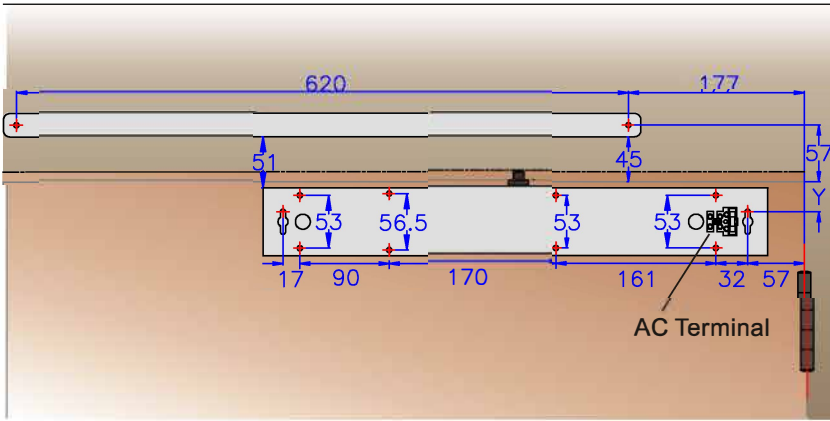

Unit : mm		
Extension	Y	
	0	30
E-15	15	45
E-30	30	60
E-50	50	80

#### ■ Installation Side View Diagram

