

Heimdall 100

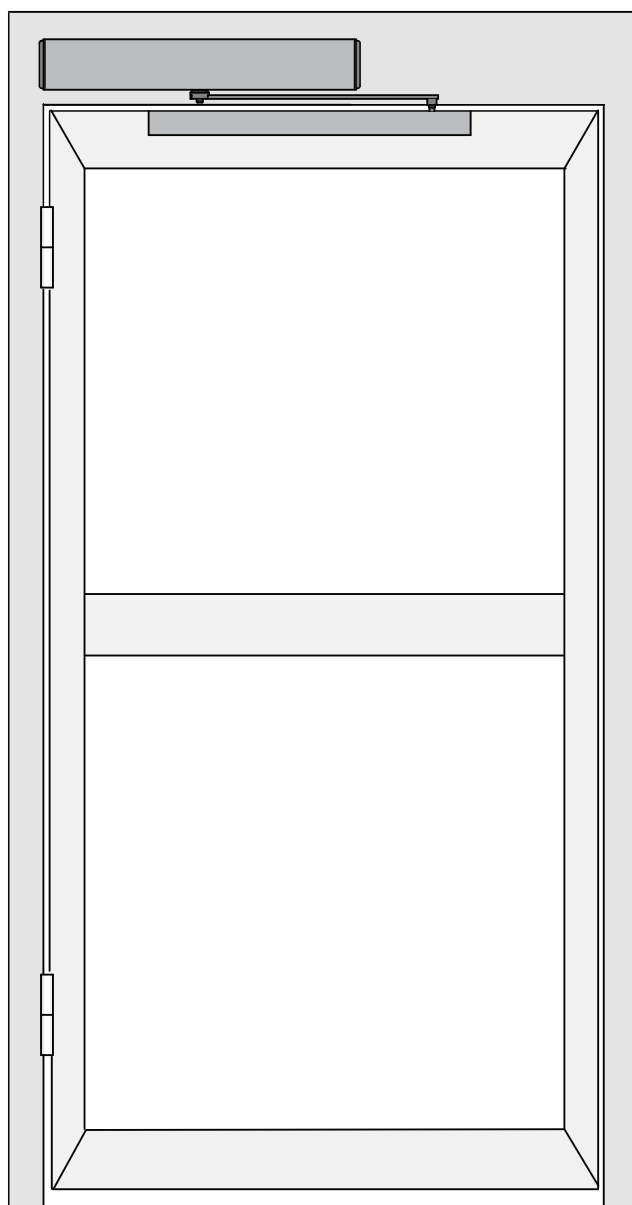

Contents

1	Technical Parameters.....	1
2	Components.....	2
3	Installation	3-9
3.1	Installation Example	3
3.2	Installation of base plate	4-5
3.3	Installation of pull arm	6
3.4	Installation of push arm	7
3.5	Installation of operation system.....	8
3.6	Installation of cover	8
3.7	Connection of operation system and pull arm.....	9
3.8	Connection of operation system and push arm.....	9
4	Electrical connection.....	10-14
5	Parameters adjustment	15

1 Technical Parameters

Supply Voltage: 100~240V

Power consumption: 50W

Opening time: 3~7s/90°

Hold open time: 1~30s adjustable

Max. door frame depth: 450mm

Door width: Min. 660mm / Max. 1200mm

Max. opening angle:120°

Environment Temperature: -20°C~+50°C

Protection class: IP12D

Product weight: 6.5Kg

Dimension: L538×H95×W90mm

mm=Door width

kg=Door weight



Suitable range



Range limit

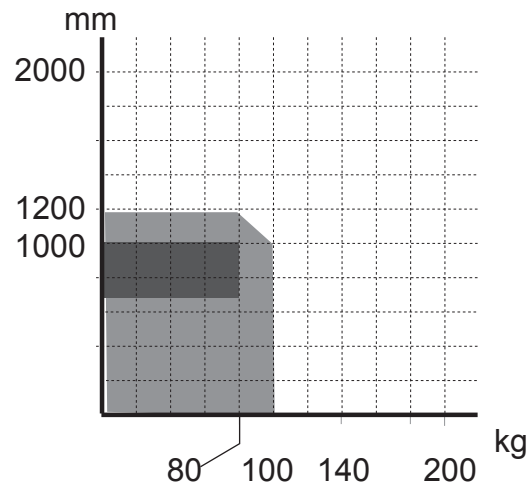

2. Components

hole for power cable

hole for sensor cable



base plate

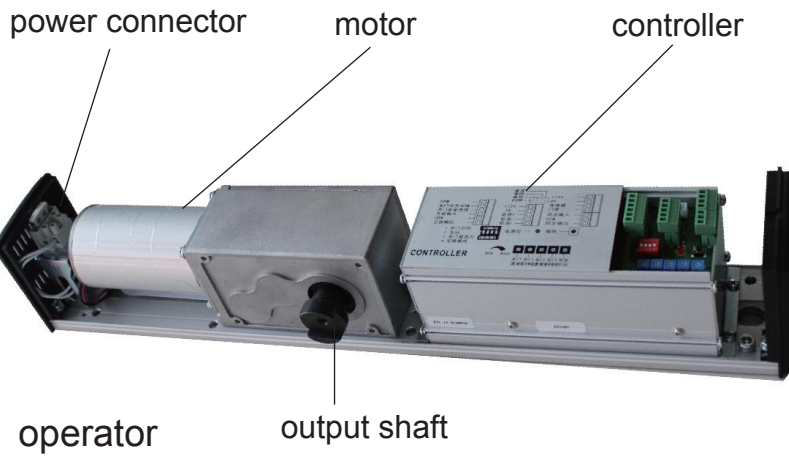

power connector

motor

controller

operator

output shaft

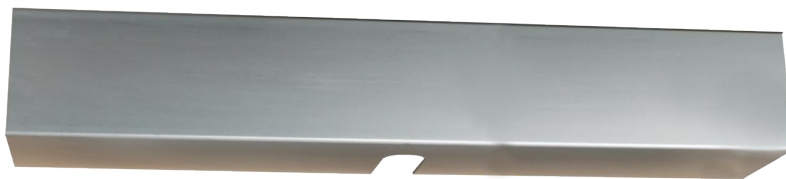

cover



pull arm(alternative)
Inward opening



push arm(alternative)
Outward opening

3. Installation

3.1 Installation example

Choose pull arm: door leaf open toward inside (operator is inside)

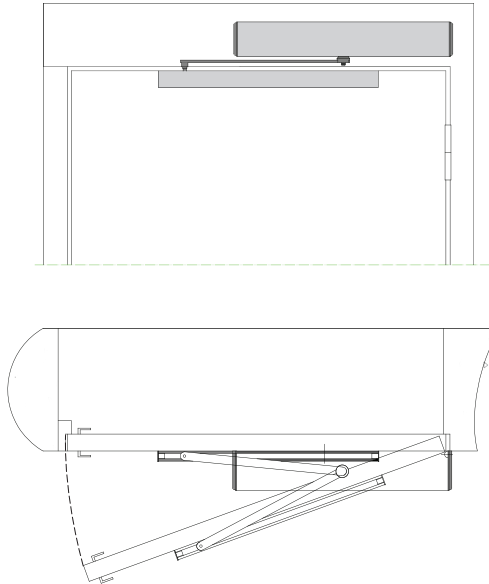

Choose push arm: door leaf open toward outside (operator is inside)

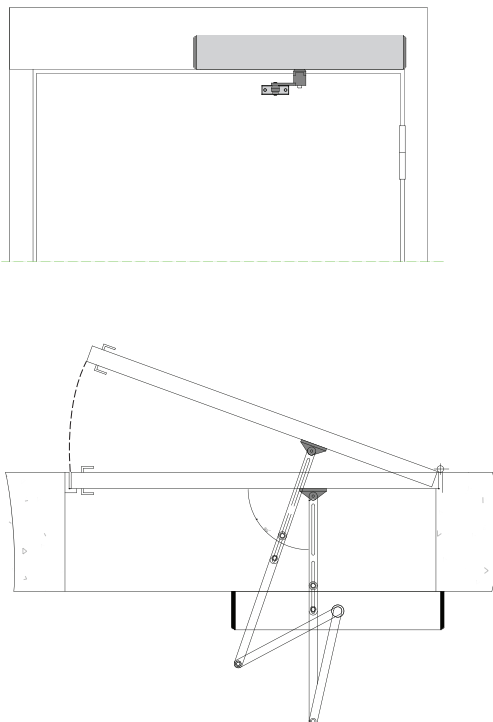

3. Installation

3.2 Installation of base plate

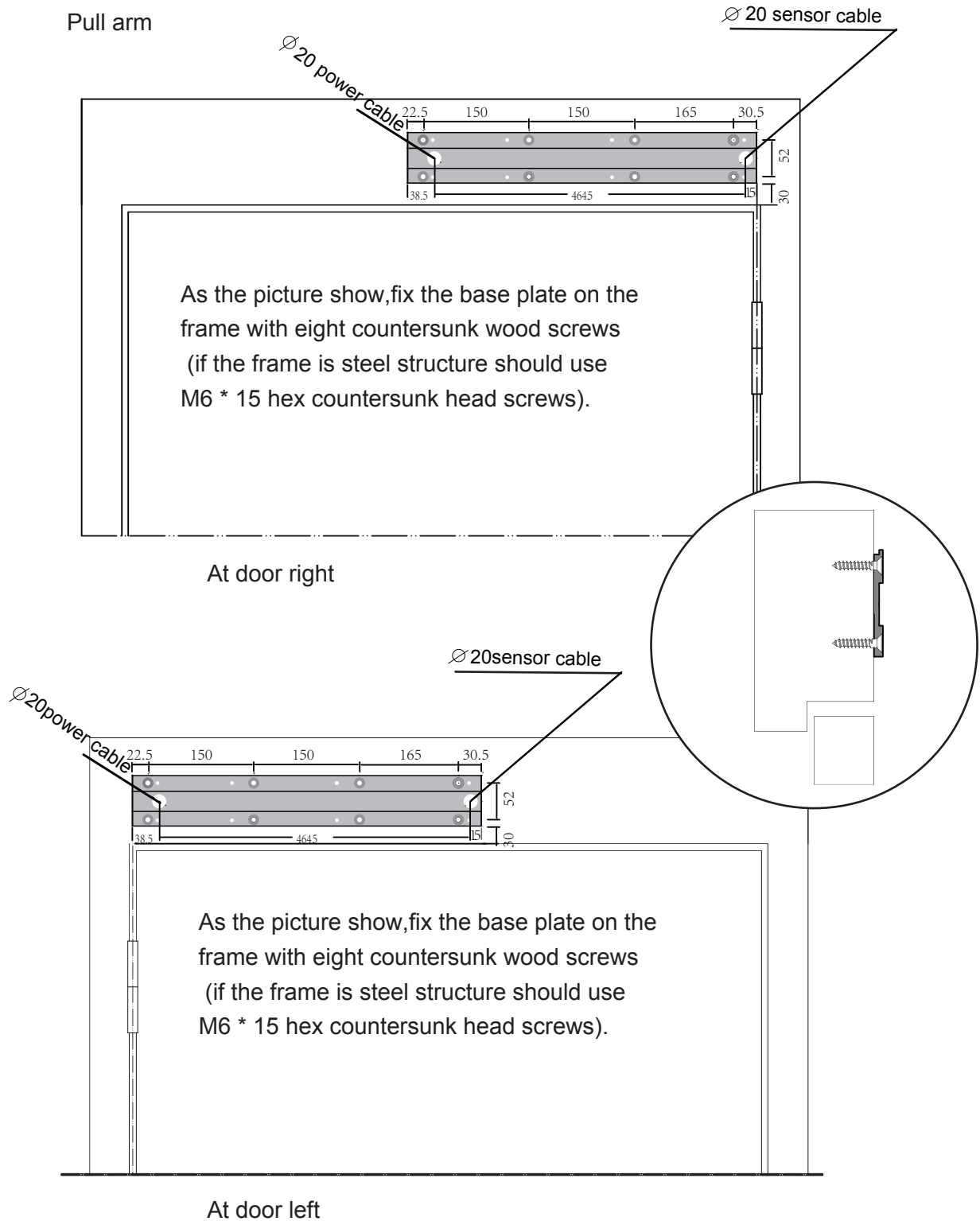

3. Installation

3.2 Installation of base plate

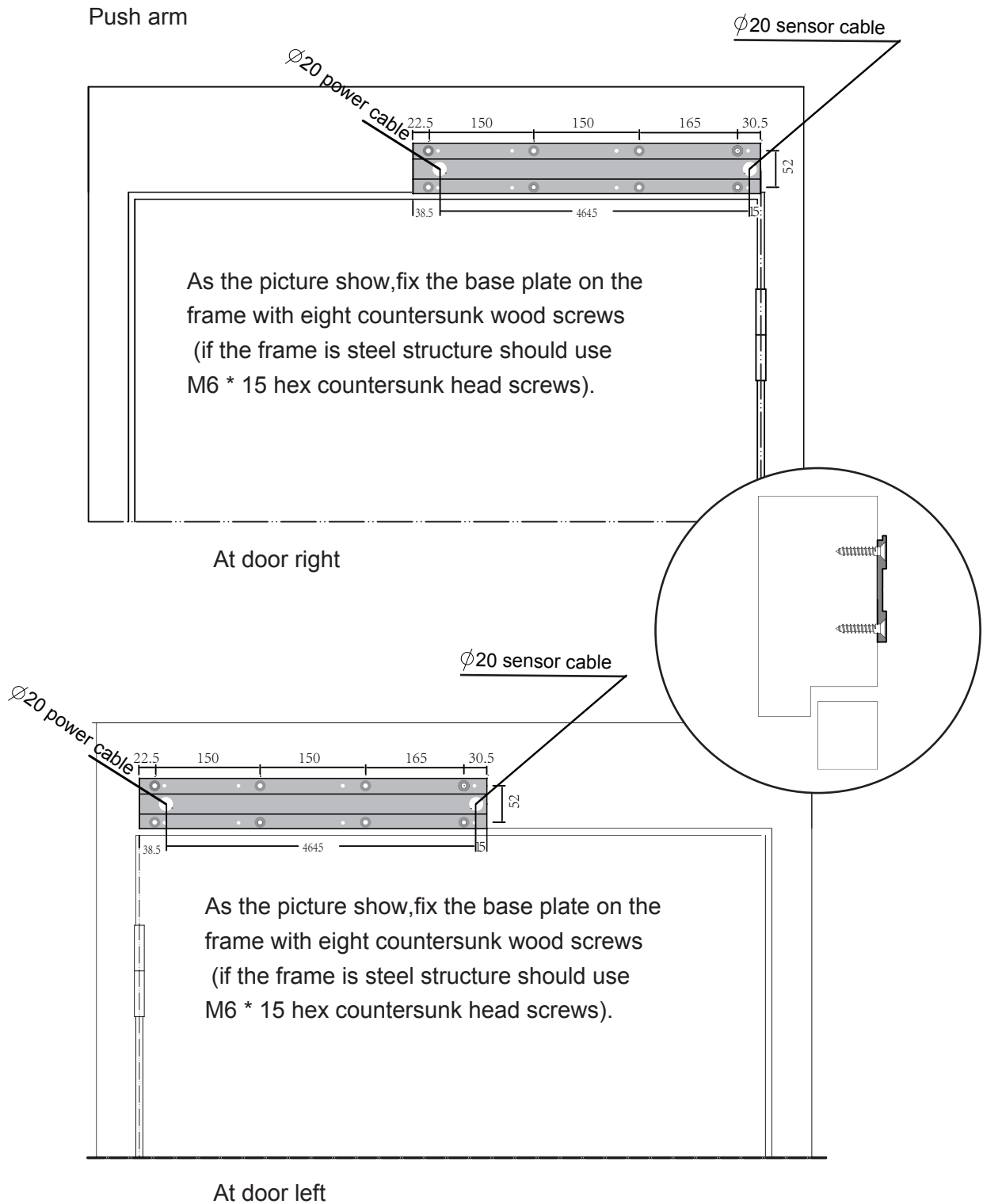

3. Installation

3.3 Pull arm

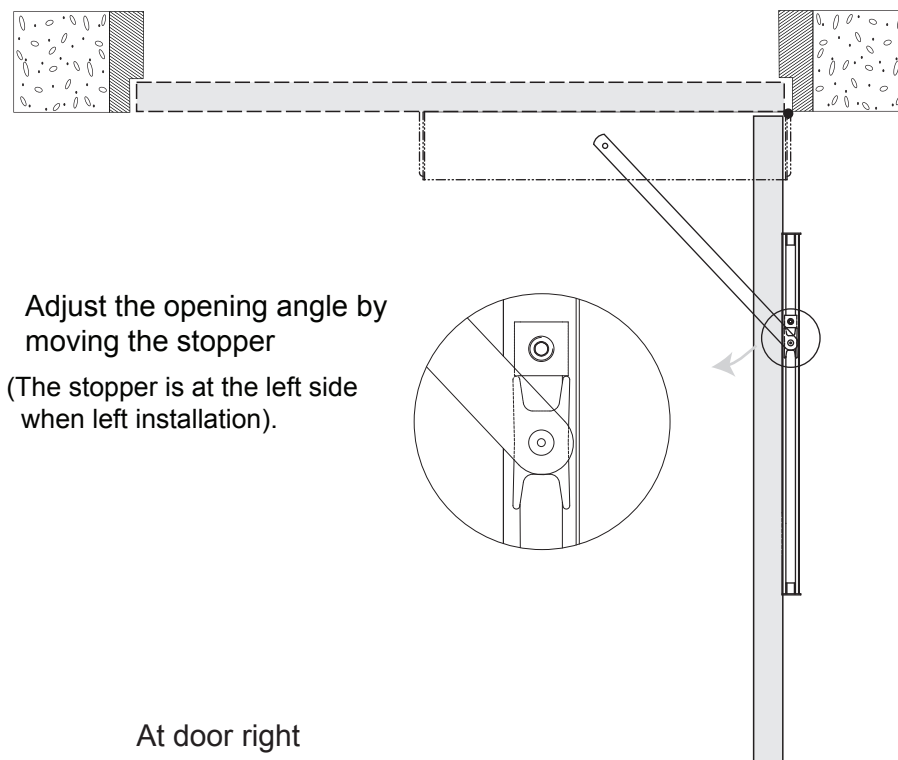
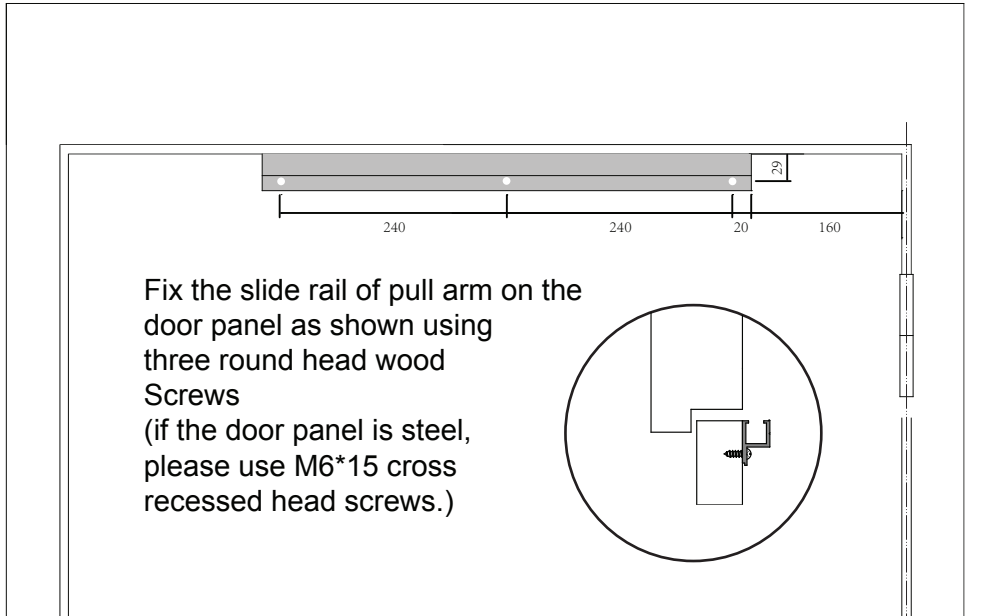

3. Installation

3.4 Push arm

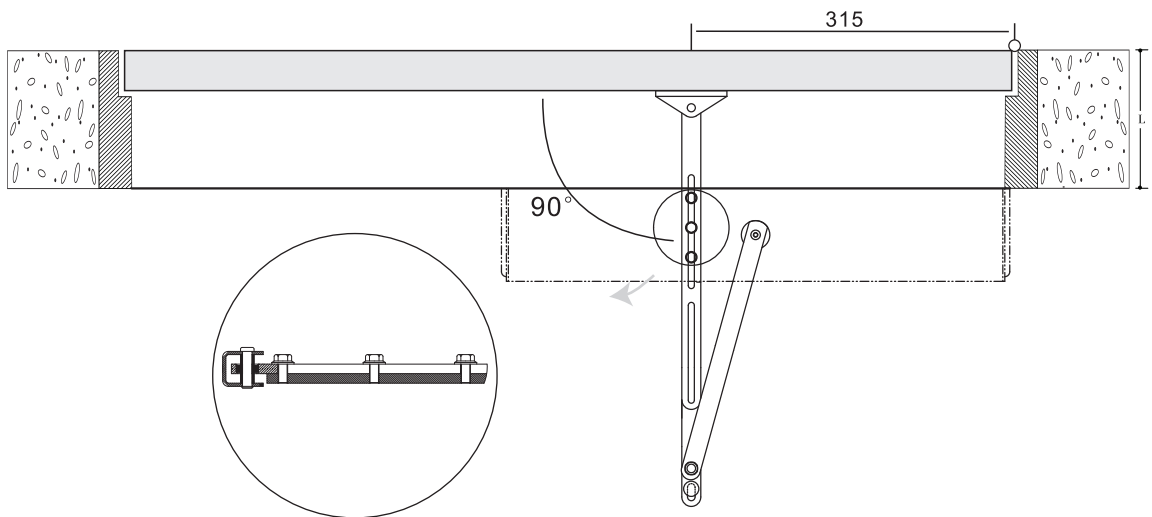
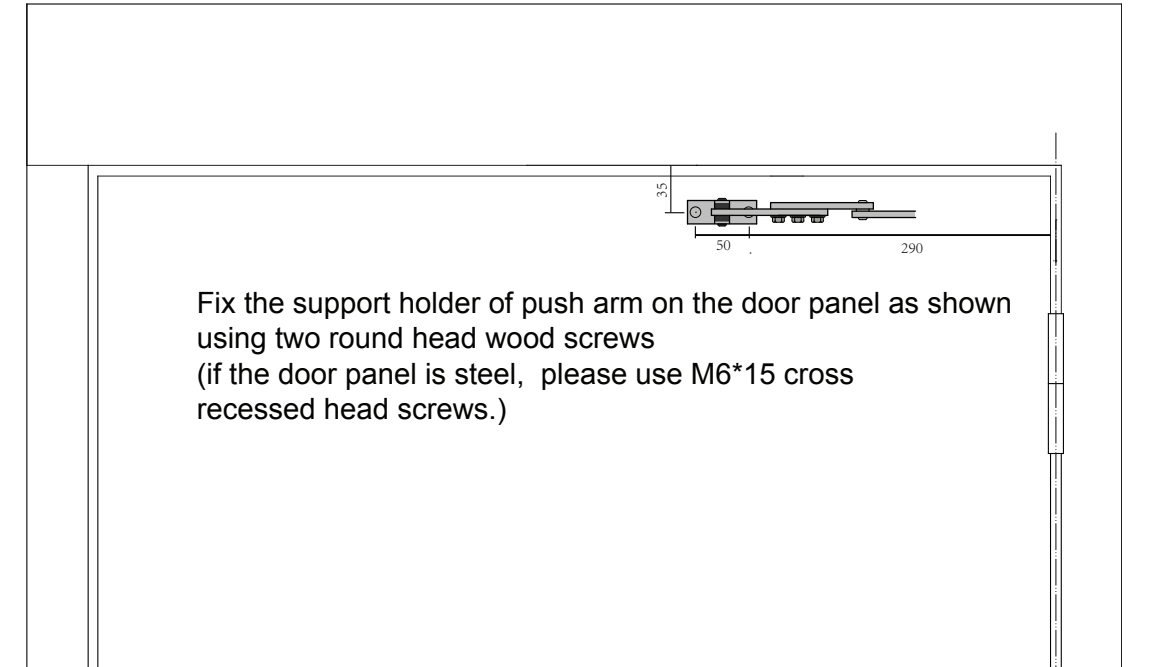

Loosen this three bolts and adjust the push arm length according to the door depth(L) until the angle between the push arm and door panel is 90° .

At door right

3. Installation

3.5 operation system

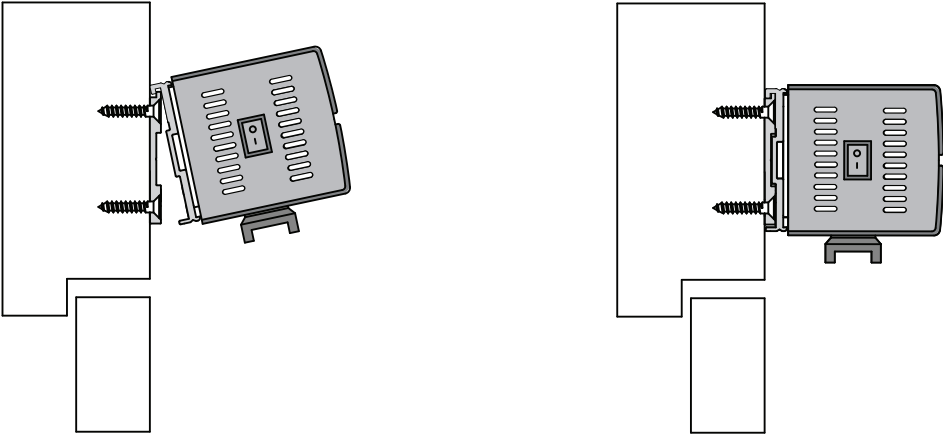

Hook the operation system on the finished base plate as shown, fix it with eight hexagon socket head screws.

3.6 Cover

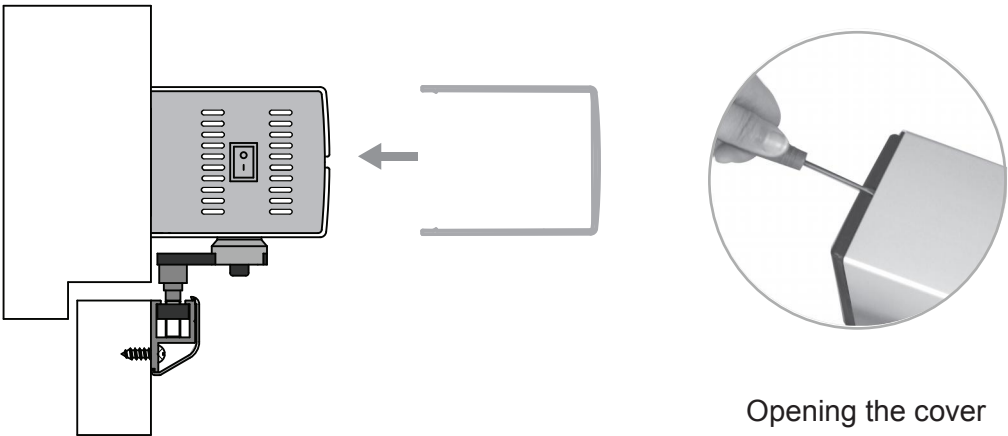

3. Installation

3.7 Connect the operation system and the pull arm

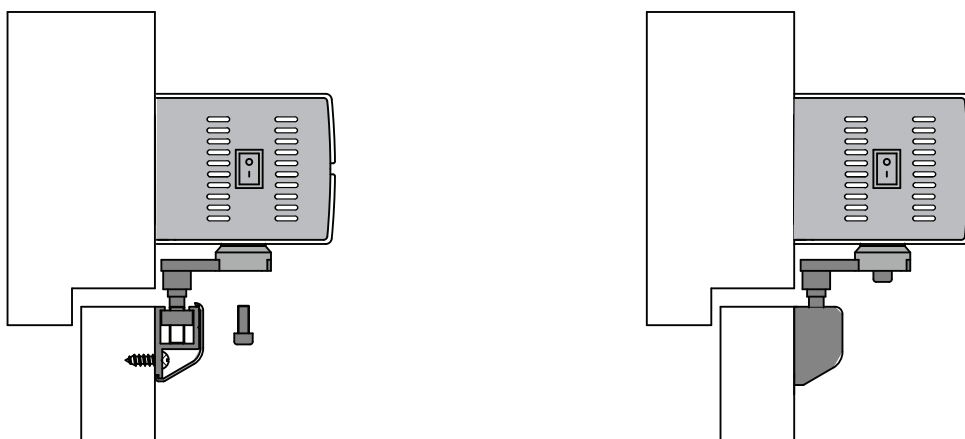

3.8 Connect the operation system and the push arm

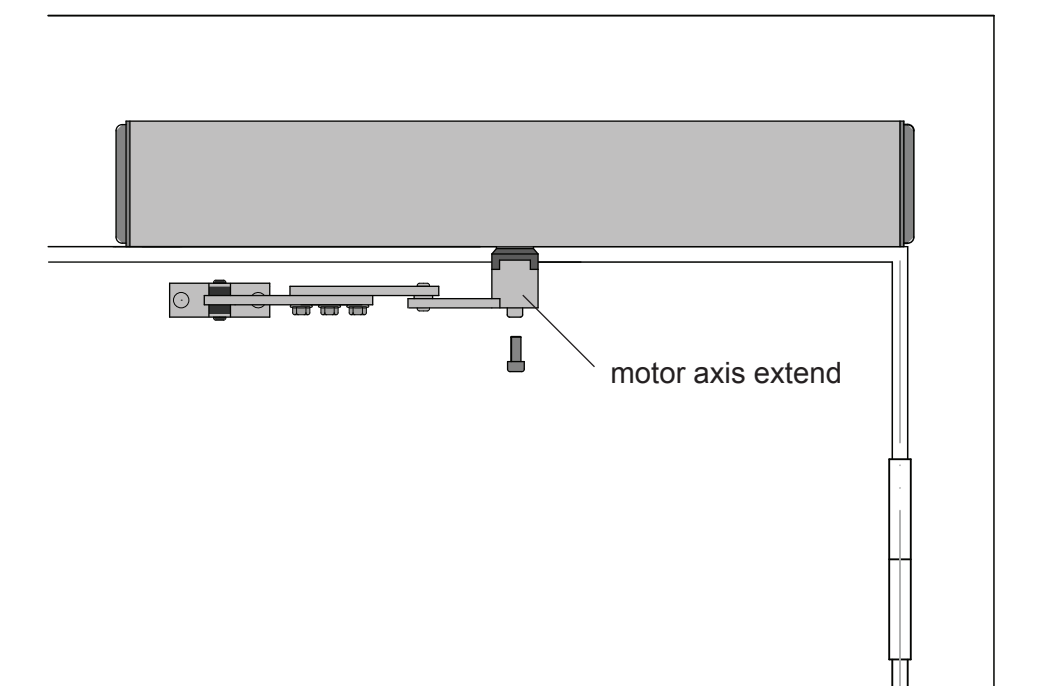

4. Electrical connection

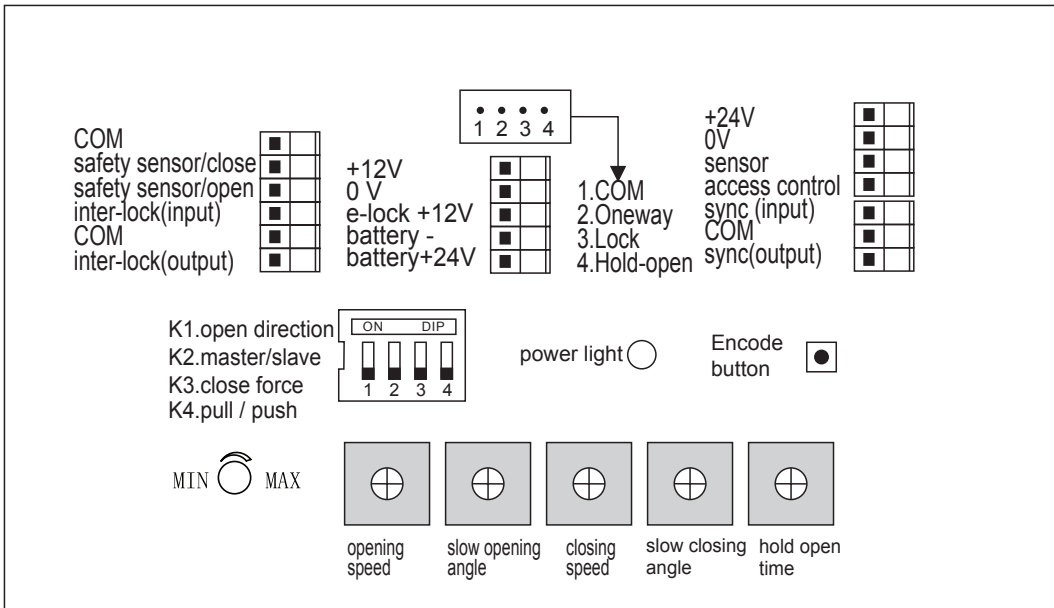
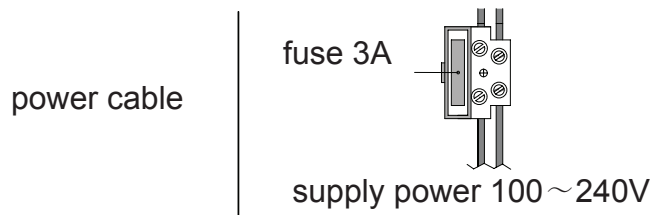

Safety sensor

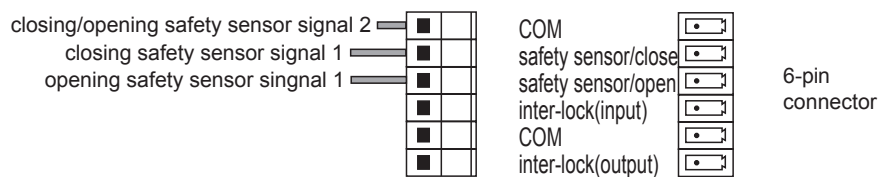

Sensor & access control

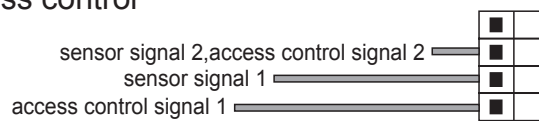

4. Electrical connection

12V power output

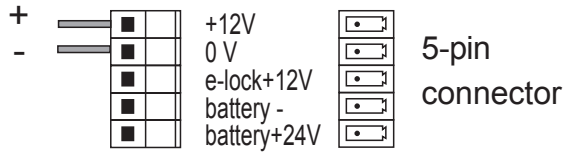

24V power output

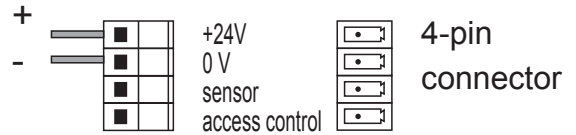

Electric lock (Automatic lock)

The door will be locked every time while it is fully closed.

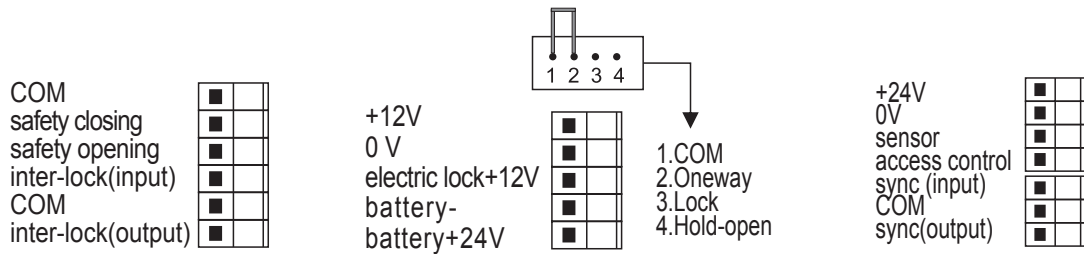

Electric lock (Remote control lock)

When the door is fully closed, press “lock” button on remote control for locking.

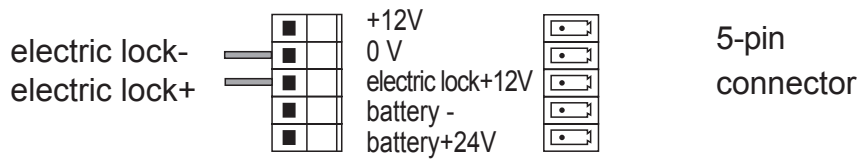

Backup battery

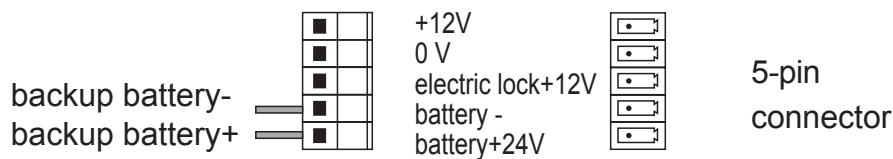

4. Electrical connection

Double-door synchronous

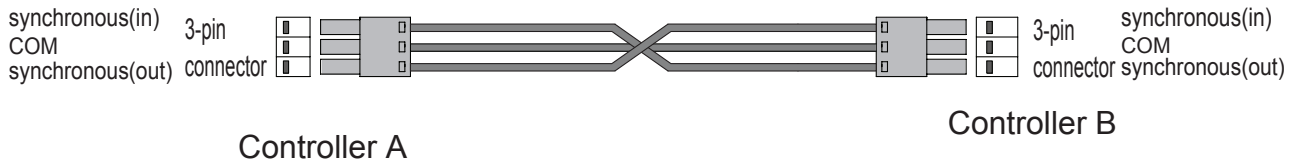

*When double opening, open first and close second is master door, close first and open second is slave door; Master door turn K2 down, slave door turn K2 up.

*Sensors and access control system are connected with the master door controller.

Inter-lock

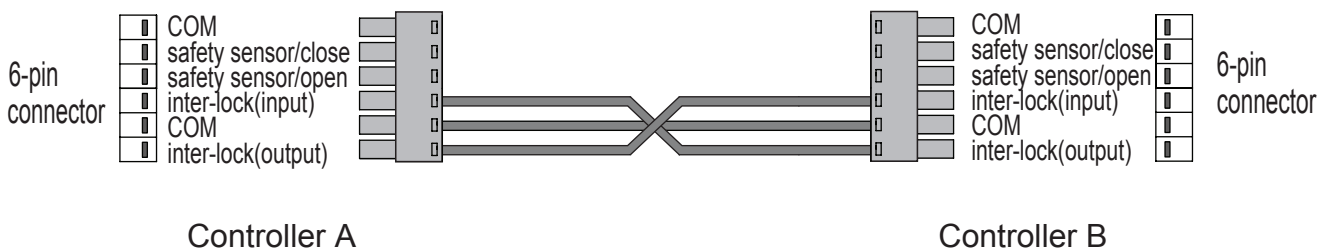

Note: Two doors share same sensor or same signal source, both doors may hold open, in this case, exchange two signal wires of the sensor which is connected with the same controller, it doesn't matter controller A or B.

4. Electrical connection

optional: Functional key switch

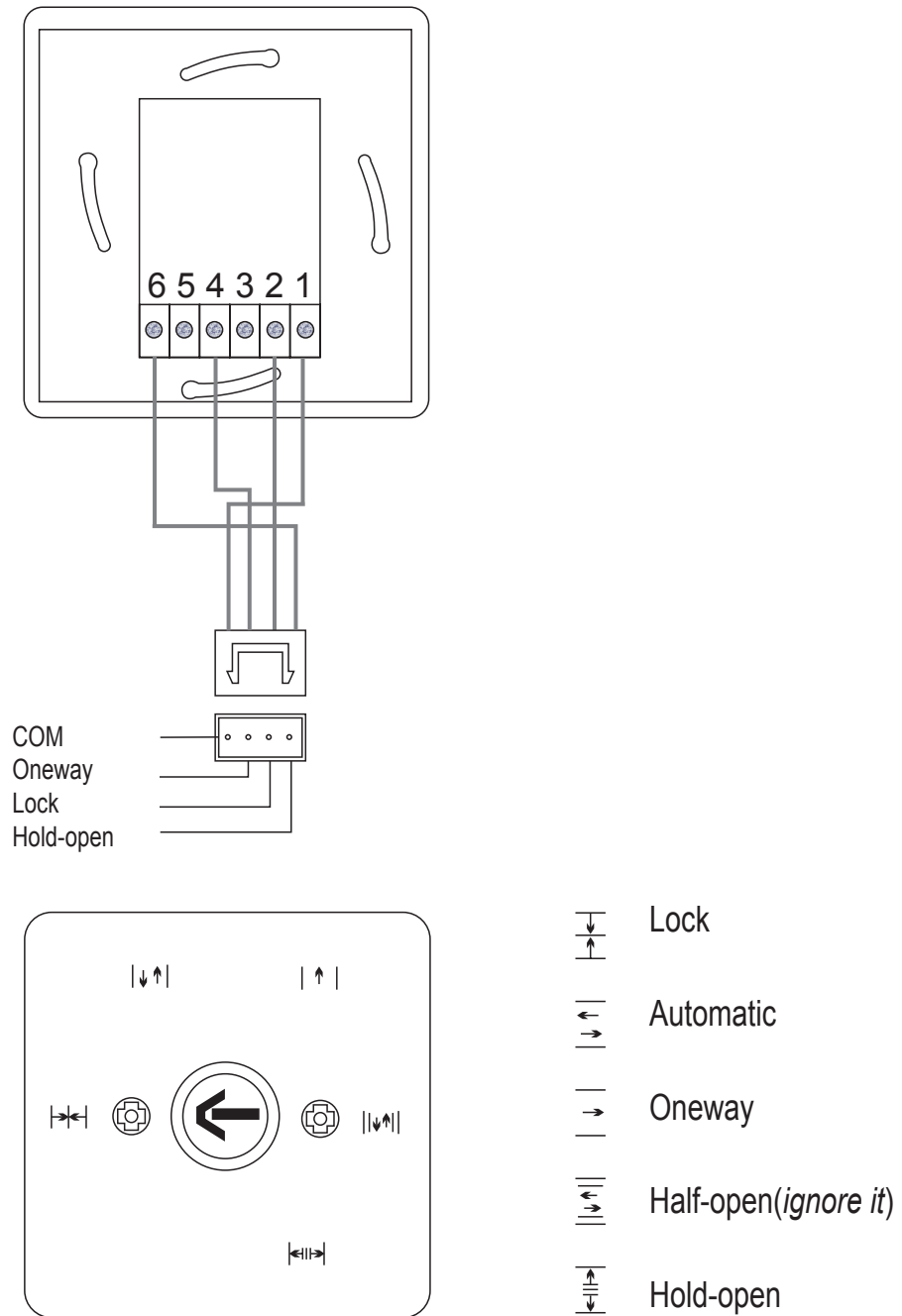

1. When the key switch is set "Oneway", the sensor signal is shielded, but the access control works normally.
2. When the key switch is set "Lock", both the sensor signal and access control are shielded.

4. Electrical connection

Optional: remote control

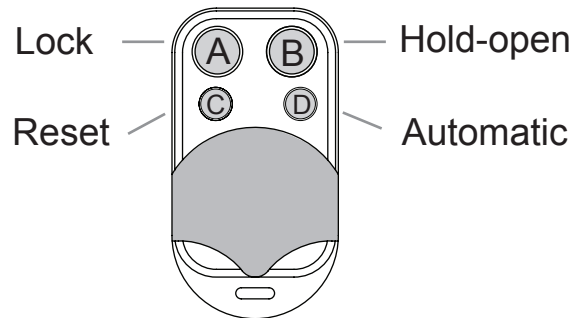

Encode remote control with the door controller :

1. Delete all: long press the button “Encode” until the sound of buzzer disappears, loosen the button.
2. Encoding: Press the button “Encode”, the buzzer sounds. Then press any button of the remote control, the buzzer stops sounding which means encoding successfully. When use the remote control, the buzzer sounds for 2 seconds.
3. Note: when use the remote control, if the buzzer “deep” twice, it means encoding failed, so please repeat above step 2.
4. Press button “automatic” one time, the door will open and close one time.

A: Lock : The sensor signal is shielded, but the access control works normally;

B: Hold-open: The door will open and hold-open until press button C to release;

C: Reset : Cancel A, B, D setting ;

D: Auto: Both the sensor signal and access control are effective .

5. Parameters adjustment

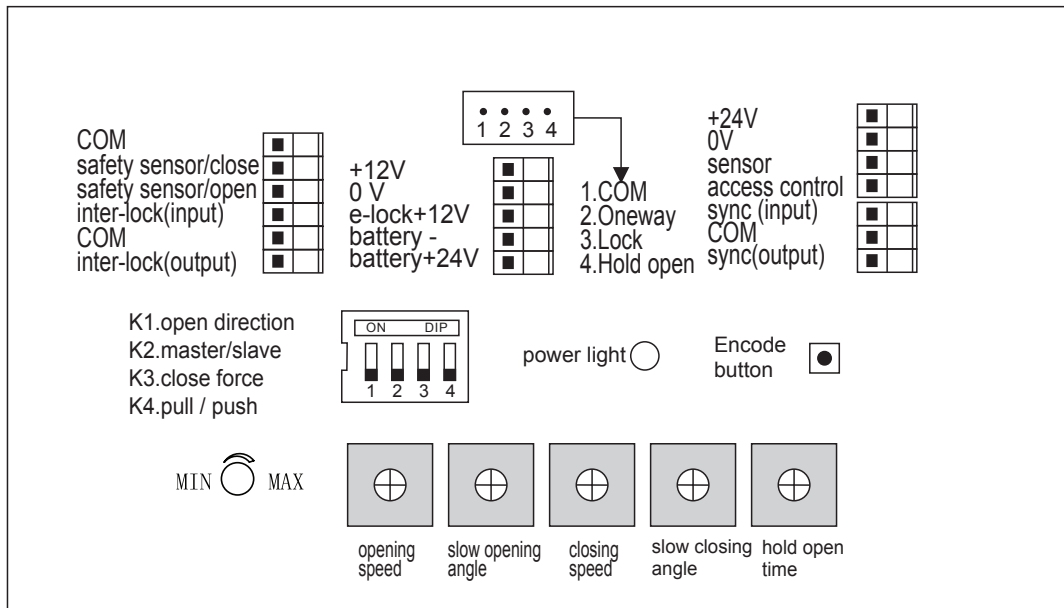

1. Set the DIP switch(K1-K4): after setting, power off and restart.

- K1: Set opening direction: power on, the door goes to closing direction, if not, turn K1 up (ON) (*turn to opposite*);
- K2: Set master/slave door: when double-door synchronous, master door turn K2 down (OFF), slave door turn K2 up (ON) ;
- K3: Set closed force: no closed force, turn K3 down(OFF), want closed force, turn K3 up (ON) ;
- K4: Choose pull arm or push arm: pull arm, turn K4 down(OFF), push arm, turn K4 up (ON) .

2. User adjustment:

- | | |
|----------------------|--------------------------------|
| 1.Opening speed | turn clockwise, speed increase |
| 2.Slow opening angle | turn clockwise, angle bigger |
| 3.Closing speed | turn clockwise, speed increase |
| 4.Slow closing angle | turn clockwise, angle bigger |
| 5.Hold-open time | turn clockwise, time longer |

Turn anticlockwise, means decrease.



The Product Has Passed ISO 9001:2015 Quality Management System Certification.